

SKF

SKF ConCentra roller bearing units for fast and reliable mounting

*Now also including tables
for inch assortment*



Contents

The SKF brand now stands for more than ever before, and means more to you as a valued customer.

While SKF maintains its leadership as the hallmark of quality bearings throughout the world, new dimensions in technical advances, product support and services have evolved SKF into a truly solutions-oriented supplier, creating greater value for customers.

These solutions encompass ways to bring greater productivity to customers, not only with breakthrough application-specific products, but also through leading-edge design simulation tools and consultancy services, plant asset efficiency maintenance programs, and the industry's most advanced supply management techniques.

The SKF brand still stands for the very best in rolling bearings, but it now stands for much more.

SKF – The knowledge engineering company



1 Product information 3

| | |
|------------------------------------------------------|-----------|
| Ready to mount and operate | 3 |
| Why SKF ConCentra roller bearing units? | 4 |
| The SKF Explorer spherical roller bearing | 5 |
| The SKF stepped sleeve..... | 6 |
| The SKF plummer block housing | 6 |
| The seals..... | 7 |
| The lubricant..... | 7 |
| A wealth of variants | 8 |
| For total economy | 10 |

2 Recommendations..... 12

| | |
|---------------------------------------------|-----------|
| Selection of bearing size | 12 |
| Design of bearing arrangements | 14 |
| Arrangement of bearing units | 14 |
| Location on the shaft | 14 |
| Attachment to the support surface..... | 15 |
| The housing surface | 17 |
| Sealing | 17 |
| Lubrication | 18 |
| Trouble-Free Operation | 20 |
| Mounting and dismantling | 21 |
| Tools | 21 |
| Mounting..... | 22 |
| Dismounting..... | 24 |

3 Product data 26

| | |
|--------------------------------------------------------|-----------|
| General product data | 26 |
| Product tables | 28 |
| ConCentra roller bearing units for metric shafts | 28 |
| ConCentra roller bearing units for inch shafts | 32 |

Other SKF bearing units..... 40

SKF – The knowledge engineering company..... 42

Ready to mount and operate

Tough jobs need tough machines and equipment which keep functioning even under difficult conditions. To do this specific bearing arrangements are needed, particularly housed bearings such as those used on conveyors, often outdoors.

Mounted roller bearings are most suitable for this type of application and often provide a cost favourable alternative to conventional bearing and housing arrangements.

The demands placed by the designer and purchaser on such products include the following.

- They should be ready to mount, i.e. the bearings should have the correct clearance and be greased and sealed.
- They should reduce operating costs. The fewer components to be bought, the fewer parts that have to be stored and documented.
- They should permit the use of commercial shafting, to save costs and machining needs.
- They must tolerate errors of alignment and shaft deflections.
- They must be easy to install on the shaft and sit firmly in position. They must be protected against contamination during mounting.
- Conditioning monitoring should be possible to avoid unplanned stoppages and prevent premature bearing replacement, just to be on the safe side.

SKF ConCentra roller bearing units are such mounted roller bearings which satisfy all these demands.



Why SKF ConCentra roller bearing units?

Quite simply because they are based on the well-proven and very successful SKF Explorer spherical roller bearings which are state-of-the-art products. Because the housings are also SKF products and SKF has determined the state of the art of bearing housings for more than 80 years.

Thus SKF know-how and wide experience of mounted bearings have been built into SKF ConCentra roller bearing units, as have quality and trouble-free operation. SKF ConCentra roller bearing units of series SYT also offer

- long service life,
- high operational reliability,
- quick mounting

and require

- little maintenance.

Simple replacement is also a valuable consideration, and the units are available wherever they may be required supported by the worldwide SKF sales organisation.

The total cost of SKF ConCentra roller bearing units is a convincing benefit as are the design characteristics.

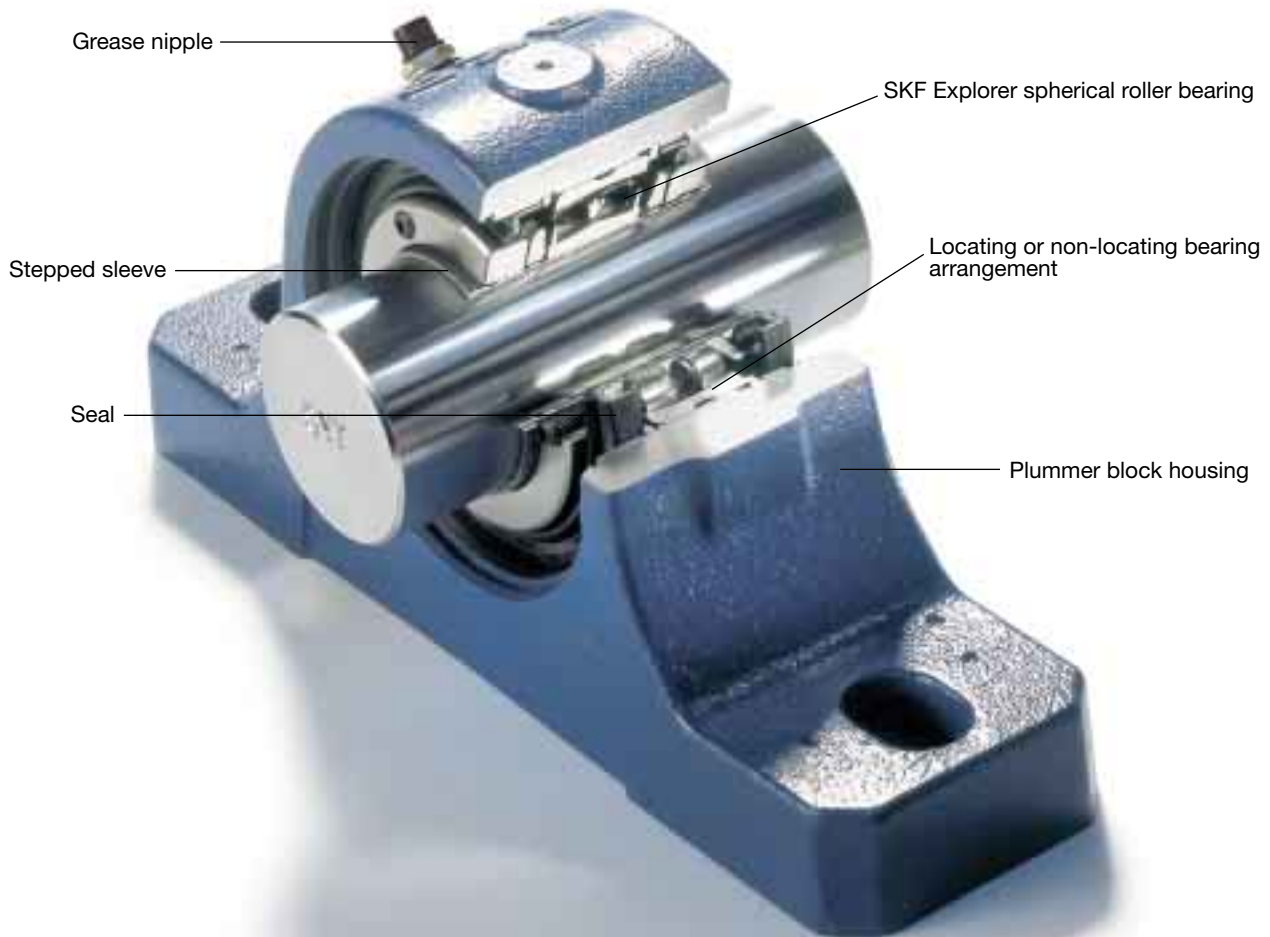

The SKF Explorer spherical roller bearing

SKF Explorer spherical roller bearings are at the heart of ConCentra roller bearing units. More significantly, they are spherical roller bearings in the 222 series, the most popular series worldwide. This means that they have proven their performance millions of times, are state-of-the-art products and have the following characteristics:

- self-alignment capability
- many long and large-diameter rollers
- symmetrical rollers with special profile
- self-guiding rollers
- floating guide ring between the roller rows
- steel window type cages

The benefits of these characteristics are long life, high operational reliability and compact design. These benefits provide opportunities for long service lives or for downsizing.

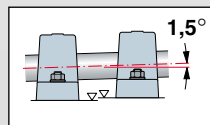

Tolerate errors of alignment

The bearings are able to align themselves and are thus insensitive to misalignments of the shaft relative to the housing.

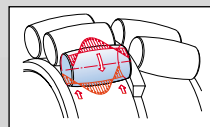

Low friction and minimum heat generation

The self-guidance of the rollers and the floating guide ring which guides the rollers axially through the unloaded zone keep friction and heat generation at a minimum.

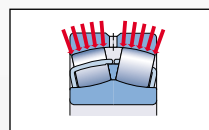

No edge stresses

The special roller profile obviates the danger of edge stresses occurring.

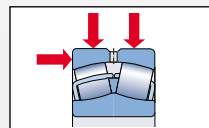

Very high load carrying capacity

The symmetrical rollers automatically position themselves providing an even distribution of load over the roller length and providing very high reliability under all load conditions.

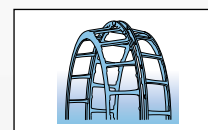

Lightweight and high strength

The steel window-type cages are lightweight but highly stable and wear-resistant. They occupy little space in the bearing leaving room for adequate lubricant supply.

SKF Explorer quality

All the bearings belong to the new performance class, referred to as SKF Explorer. SKF Explorer class spherical roller bearings live longer under heavier loads and much longer under the same loads.



The SKF stepped sleeve

The particular adapter sleeve design for the SYT units is a masterly piece of location technology. It is highly efficient and has a low cross section. The outside surface of the sleeve and the bearing bore both have a saw-toothed profile. When these profiles are axially displaced against each other a very reliable location of the bearing on the shaft will be achieved. The operation is exceedingly simple.

The benefit for the user is very quick assembly. It is simply a matter of pushing the unit along the shaft and then bolting it to the support.

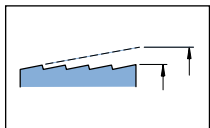

The saw-toothed profile

The requirements were clear and simple – a sleeve was required having a relatively steep angle of taper but at the same time a low cross section. The SKF answer is equally clear and simple – the sleeve and bearing bore both have a profile which consists of several equal tapered sections arranged one after another.

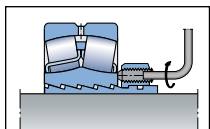

The reliable fixation

To obtain this a mounting ring with grub (set) screws has been added to the adapter sleeve. By tightening the screws the inner ring is pushed axially along the sleeve and locked in position.

The SKF plumber block housing

Robust non-split plumber (pillow) block housings of grey cast iron enclose the bearings and efficiently protect them from external mechanical damage. The stiff design helps the housings to retain their form. The holes for the attachment bolts are cast. All housings are provided with a grease nipple, allowing lubricant to be supplied direct to the bearing.

The housings of the SYT units are based on the SNL plumber block housings of Dimension Series 5 – another state-of-the-art SKF product – and have the same high stiffness and good heat conducting properties. They can also be quickly adapted to individual applications.

If required it is also possible to supply housings made of spheroidal graphite cast iron. The units are then identified by a D in the designation prefix: SYTD.

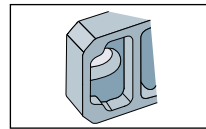

Stiff design

The base of the SYT housings is reinforced. This reinforcement also surrounds the holes for attachment bolts providing a reliable hold on the support surface. The preload forces of the bolts provide good contact with the support to make sure that the housing base and thus the housing as a whole cannot deform.

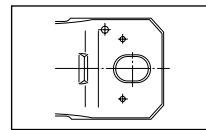

Markings for additional holes

The most suitable positions for additional holes are clearly indicated on the casting. For example, if the housings are to be installed on T beams, four additional holes for attachment bolts can be drilled at the indicated positions. The most appropriate position for the attachment of permanent condition monitoring sensors is also indicated.

The seals

The integral seals contribute to the compactness of the ConCentra roller bearing units. The factory grease fill provides a suitable amount of the correct lubricant from the outset. These features make the ConCentra roller bearing units ready to mount and operate at a modest cost.

There is a choice of two seal designs and both accommodate misalignment and axial movements. End covers are also available for SYT housings mounted on shaft ends.

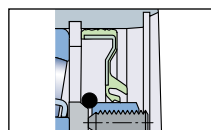

Double-lip seals

These seals allow excess grease to exit but exclude solid contaminants and moisture; the operating temperature range is -50 to +100 °C.

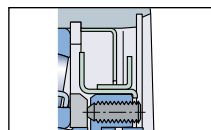

Labyrinth seals

These allow high-speed operation and the limit to the operating temperature is set by the grease rather than the seal.

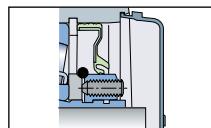

End covers

To protect shaft ends and prevent accidents. The operating temperature range is -20 to +100 °C.

The lubricant

In order for ConCentra roller bearing units to perform correctly they are filled with SKF LGEP 2 grease. This is a light-brown, high-quality lithium thickener grease with EP additives and a mineral base oil and is characterised by

- good lubricating properties under heavy loads and at low speeds,
- minimal lubricant loss under severe operating conditions,
- excellent ageing resistance,
- excellent water resistance, and
- very good rust inhibiting properties.

Well lubricated

The SKF LGEP 2 grease is well suited for ConCentra roller bearing unit applications; it fills between 30 and 50 % of the free space in the housing.

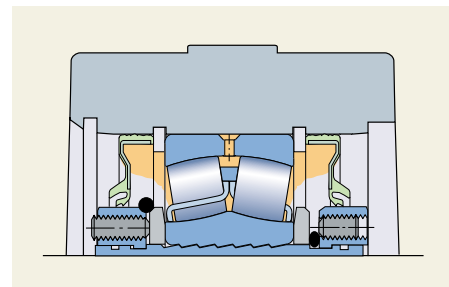

A wealth of variants

The standard range of SKF ConCentra roller bearing units comprises SYT plummer block units for 35 to 75 mm diameter metric shafts, thus covering most market needs. To meet individual requirements, they are available as

- non-locating bearing units as well as
- locating bearing units.

These units are shown in the product table on **pages 28 and 29**.



Additional series for inch shafts

The standard range of ConCentra roller bearing units for metric shafts is complemented by several series and sizes of plummer block bearing units for inch-size shafts of diameter 1 7/16 to 4 in, inclusive. These differ slightly in their dimensions and designs. The range includes units in the

- SYR .. N series,
- SYE .. N series and
- FSYE .. N series.

based on the SYR, SYE and FSYE plummer block units which have been successful on the American market for many years. The most important technical data for these units for inch-size shafts will be found on **pages 32 to 39**.

Locating or non-locating arrangements

Generally two bearings are required to support a rotating machine component: a locating bearing and a non-locating bearing. Consequently the SKF ConCentra roller bearing units are available in two versions – a locating design and a non-locating design.

A choice of seals

Difficult environments with a lot of dust, dirt and dampness call for strong seals. For such environments the double-lip seals are the answer. For operation at higher speeds and when the environment is not so severe, the labyrinth seals are more appropriate. Both seals are standard equipment.

Another choice

The standard housings are made of grey cast iron. If even greater strength is needed, housings of spheroidal graphite cast iron can be supplied.

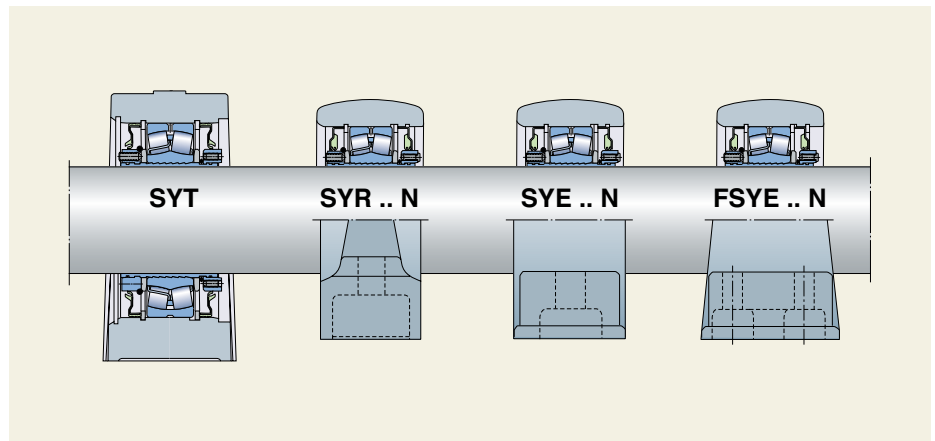

The ConCentra roller bearing unit designs

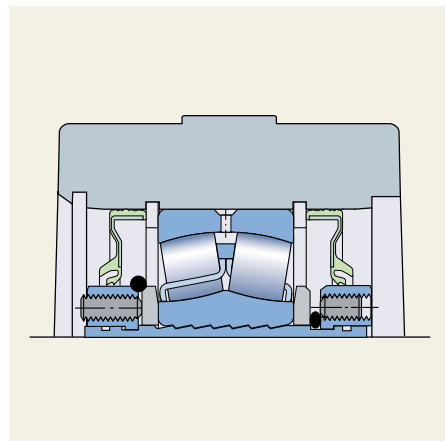

Locating bearing arrangement

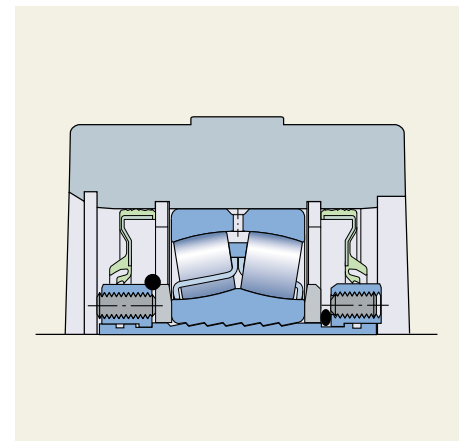

Non-locating bearing arrangement

Double-lip seal

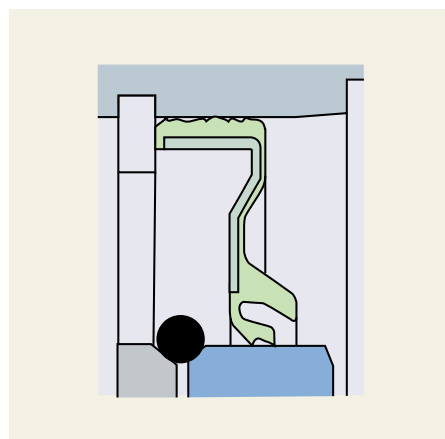

Labyrinth seal

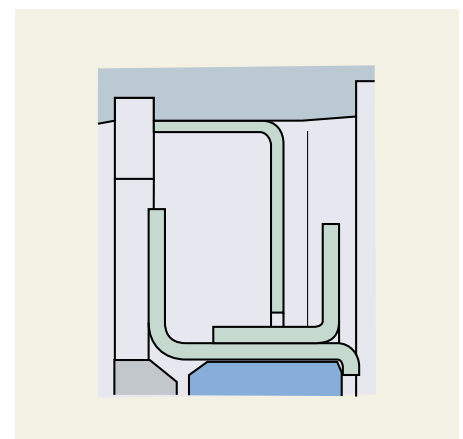

For total economy

The high load carrying capacity and high reliability, the robust design and easy maintenance, and above all, the simple and rapid mounting mean that SKF ConCentra roller bearing units are appropriate for a wealth of applications. For example, consider the operating conditions bearing arrangements have to withstand in quarrying equipment.

They are usually exposed to the weather as well as dust and dirt, have to carry heavy loads and survive impacts and in spite of this should last for a long while. Or units in a sawmill. Dust and sawdust are everywhere, getting into everything, and may even be mixed with water.

If the bearings should fail, they can very easily be replaced on site – by the ready-to-mount, ready-to-operate pre-greased and sealed units with pre-set clearance which cannot become contaminated during mounting – the SKF ConCentra roller bearing units.

Applications

- Mining and metallurgical equipment
- Refining equipment
- Belt, bucket and chain conveyors
- Large washing installations
- Agricultural and forestry machinery
- Food and beverage processing equipment
- Fans and blowers
- Mixers, crushers and screens
- Light rail vehicles
- Wastewater treatment equipment
- Commercial laundry equipment

Requirements

- Ready to mount and operate
- Robust design
- Strong and reliable
- Efficiently sealed
- Grease pre-lubricated
- Can be relubricated
- Simple location on shaft
- Insensitive to misalignment
- Condition monitoring possible

Solution





1



Selection of bearing size

The life-extending improvements embodied in SKF Explorer spherical roller bearings can best be understood using the equation for SKF rating life which is in accordance with ISO 281:1990/Amd 2:2000. This calculation method constitutes an extension of the fatigue life theory and is better able to predict bearing life. For roller bearings

$$L_{nm} = a_1 a_{SKF} L_{10}$$

or

$$L_{nm} = a_1 a_{SKF} \left(\frac{C}{P}\right)^{10/3}$$

If the speed is constant, it is often preferable to calculate the life expressed in operating hours using

$$L_{nmh} = a_1 a_{SKF} \frac{1\,000\,000}{60 n} \left(\frac{C}{P}\right)^{10/3}$$

where

L_{nm} = SKF rating life (at 100 – n % reliability), millions of revolutions

L_{nmh} = SKF rating life (at 100 – n % reliability), operating hours

L_{10} = basic rating life (at 90 % reliability), millions of revolutions

a_1 = life adjustment factor for reliability (→ **table 1**)

a_{SKF} = SKF life modification factor (→ **diagram 1**)

C = basic dynamic load rating, kN

P = equivalent dynamic bearing load, kN

n = rotational speed, r/min

a_{SKF} factor

The a_{SKF} factor represents a very complex relationship between various influencing factors including contamination and lubrication. Lubrication conditions are expressed by the viscosity ratio κ . Values of a_{SKF} can be obtained from **diagram 1** for different values of η_c (P_v/P) and κ . This could also be calculated by using the “SKF Interactive Engineering Catalogue” on CD-ROM or online at www.skf.com.

Diagram 1 has been drawn up for a safety factor commonly used in fatigue life considerations.

Equivalent dynamic bearing load

The equivalent dynamic bearing load for spherical roller bearings can be obtained from

$$P = F_r + Y_1 F_a \quad \text{when } F_a/F_r \leq e$$

$$P = 0,67 F_r + Y_2 F_a \quad \text{when } F_a/F_r > e$$

where

P = equivalent dynamic bearing load, kN

F_r = actual radial bearing load, kN

F_a = actual axial bearing load, kN

Y_1, Y_2 = axial load factors for the bearings

e = calculation factor

Appropriate values of the factors e , Y_1 and Y_2 will be found in the product tables for each individual bearing.

Life adjustment factor a_1

| Table 1 | |
|----------------|--------------|
| Reliability % | Factor a_1 |
| 90 | 1 |
| 95 | 0,62 |
| 96 | 0,53 |
| 97 | 0,44 |
| 98 | 0,33 |
| 99 | 0,21 |

Example

For a ConCentra roller bearing application following example could be applicable during normal circumstances:
 The operating conditions for ConCentra roller bearing unit SYT 40 L, including SKF Explorer class bearing 22208 E, are:

- equivalent dynamic bearing load $P = 12 \text{ kN}$
- viscosity ratio $\kappa = 3$
- contamination factor $\eta_c = 0,5$
- basic load rating $C = 96,5 \text{ kN}$
- fatigue load limit $P_u = 9,8 \text{ kN}$
- life adjustment factor $a_1 = 1$
- rotational speed $n = 1\,000 \text{ r/min}$

Thus

$$\eta_c (P_u/P) = 0,5 (9,8/12) = 0,41$$

Using **diagram 1** and $\kappa = 3$ gives $a_{SKF} \approx 6$.

Using formula

$$L_{nmh} = a_1 a_{SKF} \frac{1\,000\,000}{60 n} \left(\frac{C}{P}\right)^{10/3}$$

then gives

$$L_{10mh} = 1 \times 6 \times \frac{1\,000\,000}{60 \times 1\,000} \times \left(\frac{96,5}{12}\right)^{10/3} \approx 104\,000 \text{ h}$$

Further information on selection of bearing size can be found in the SKF General Catalogue or the “SKF Interactive Engineering Catalogue” on CD-ROM or online at www.skf.com.

Diagram 1

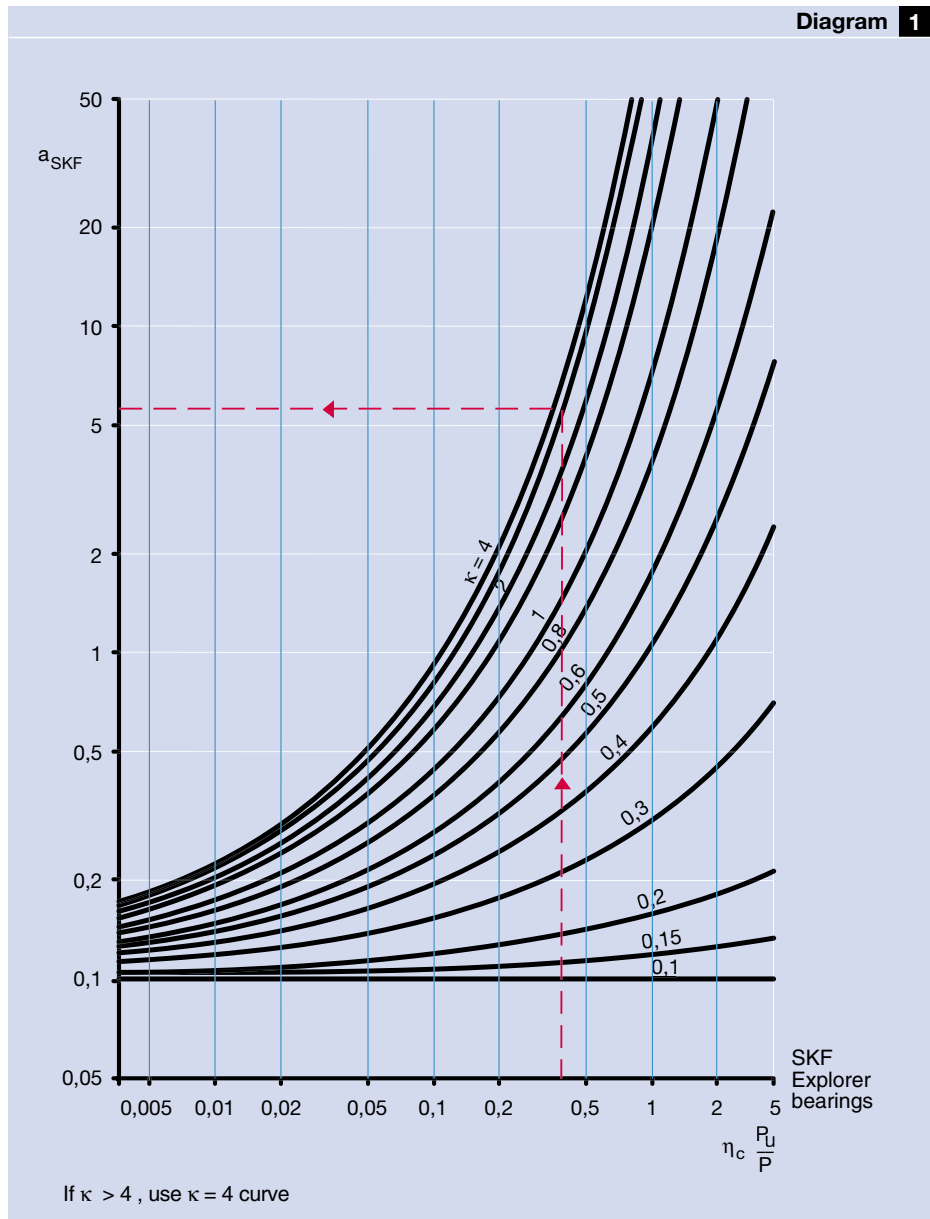

Factor a_{SKF} for SKF Explorer spherical roller bearings

Design of bearing arrangements

Arrangement of bearing units

To support a rotating component, e.g. a shaft, two ConCentra roller bearing units are required: a locating bearing unit and a non-locating bearing (→ **fig 1**).

The locating bearing unit at one end of the shaft supports it radially and locates it axially in both directions. The non-locating bearing unit at the other end also provides radial support and must allow axial displacements resulting from thermal changes in shaft length to take place. These are accommodated between the bearing outer ring and the housing bore.

The locating bearing unit should be arranged at the drive side (→ **fig 1**).

Location on the shaft

Shaft requirements

The special method of securing the ConCentra roller bearing units to the shaft allows the use of commercial shafting.

Tolerances

In normal cases shafts machined to tolerance h9 can be used. The cylindricity as defined in ISO 1101:1996 should be according to IT5/2. For less demanding applications h10 and IT7/2 may be satisfactory.

Surface finish

The surface roughness R_a to ISO 4288:1996 for the sleeve seating should not exceed $3,2 \mu\text{m}$.

Other components on the shaft

In order to allow the units to be dismounted easily, a space of at least 40 mm should be left between the unit and adjacent components on the shaft (→ **fig 2**). This is necessary to provide access to the grub screws in the ring at the "DISMOUNT.SIDE". The mounting and dismounting sides are marked on the housing (→ **fig 3**).

Bearing arrangements at shaft ends

To protect bearing arrangements on the ends and to avoid accidents, end covers are available for ConCentra roller bearing units of series SYT. These plastic covers are suitable for operating temperatures from -20 to $+100 \text{ }^\circ\text{C}$ and are snapped into recesses in the housing bore.

The appropriate cover for a particular unit will be found in **table 1** which also provides the value of the cover protrusion.

Arrangement of bearing units

Fig 1

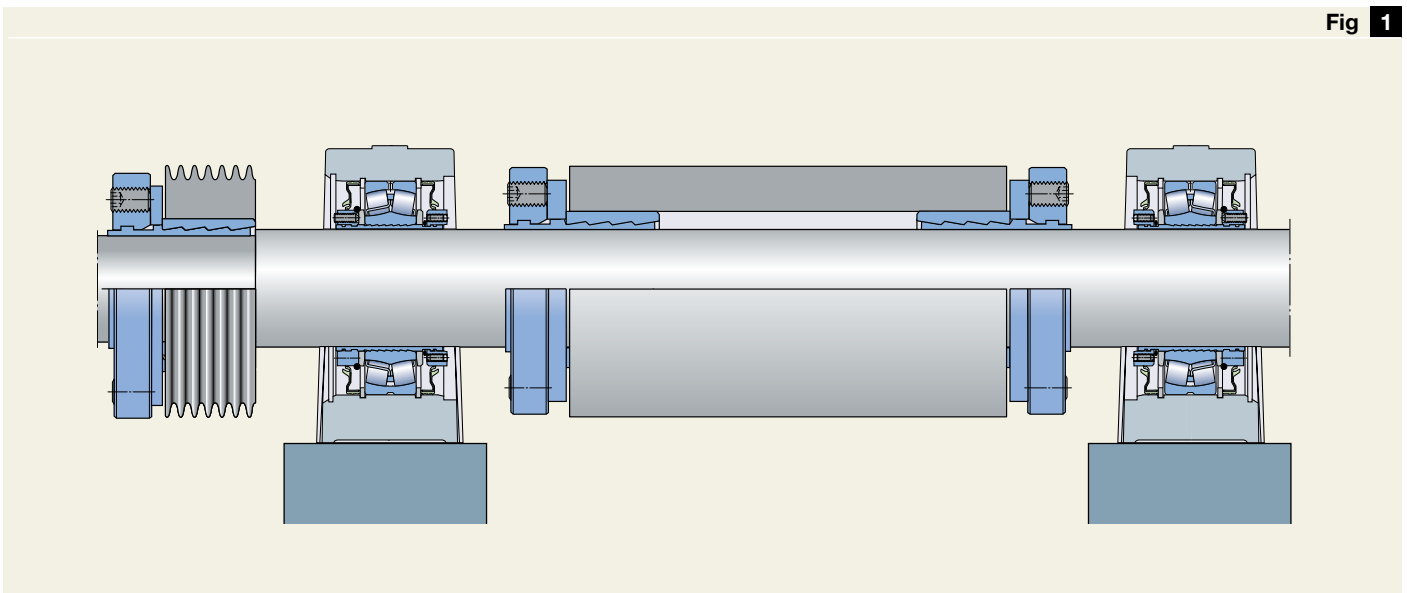
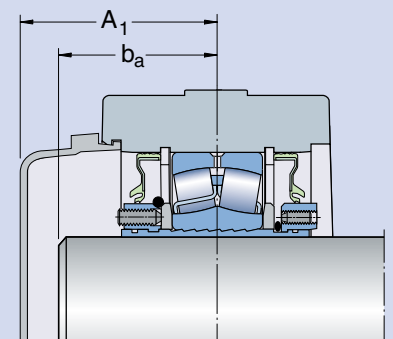

Table 1



Attachment to the support surface

ConContra roller bearing units have holes in the feet to take attachment bolts. The holes allow subsequent adjustment of housing position.

Support surface

To provide operational reliability and a long service life for the units, it is recommended that the support surface should have a surface roughness $R_a \leq 12,5 \mu\text{m}$. The flatness tolerance (planicity) should lie within IT7.

Holes for attachment bolts

The ConContra roller bearing units of series SYT have two cast holes in the feet as standard. It is possible to drill four additional holes in the series SYT units if required by the application. The positions where these holes should be drilled are indicated on the casting. Details of the positions and suitable dimensions for these holes will be found in **table 2** on **page 16**.

Attachment bolts

Hexagonal headed bolts to ISO 4014: 1988 are recommended. Where loads act vertically towards the support surface, bolts of strength 8.8 are adequate. If the loads act at other angles stronger bolts to class 10.9 may be necessary. The recommended tightening torques for class 8.8 bolts are given in **table 3** on **page 16**.

| Unit Basic designation | End cover Dimensions b_a | | A_1 | Designation |
|------------------------------|----------------------------------|-----|-------|-------------|
| | max | min | | |
| – | mm | | – | – |
| SYT 35 | 43 | 34 | 50 | ECY 207 |
| SYT 40 | 43 | 34 | 51 | ECY 208 |
| SYT 45 | 43 | 34 | 52 | ECY 209 |
| SYT 50 | 55 | 34 | 62 | ECY 210 |
| SYT 55 | 55 | 34 | 66 | ECY 211 |
| SYT 60 | 65 | 38 | 73 | ECY 212 |
| SYT 65 | 65 | 38 | 73 | ECY 213 |
| SYT 70 | 70 | 38 | 80 | ECY 214 |
| SYT 75 | 70 | 38 | 80 | ECY 215 |

End covers for shaft end bearing arrangements

Minimum distance to adjacent components

Fig 2

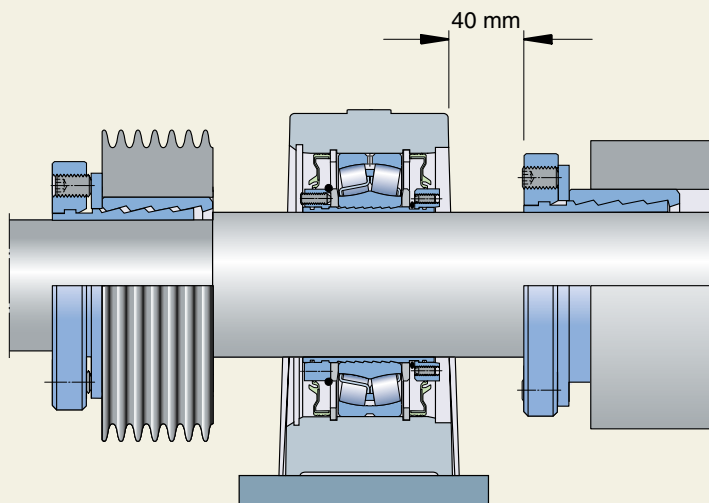

Bearing unit marking

Fig 3

SYT 60 L

← MOUNT.SIDE | DISMOUNT.SIDE →

Dismounting Instructions

- 1: Side with only two screws is **Dismounting** side.
- 2: Using 3 mm hex key, adjust screws as follows.
- 3: First snug up, then loosen **Mounting** side screws.
- 4: Alternately tighten **Dismounting** side screws in 1/4 turn increments until shaft rotates freely in bearing, or POP is heard.

Relubricate with SKF grease LGEP2 or equivalent

SKF ConContra
Patented product

Table 2

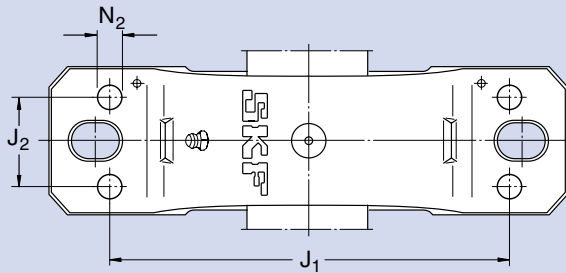

| Unit Basic designation | Dimensions | | | Appropriate bolt size |
|------------------------------|----------------|----------------|----------------|--------------------------|
| | J ₁ | J ₂ | N ₂ | |
| – | mm | | | – |
| SYT 35 | 160 | 34 | 11 | M 10 |
| SYT 40 | 160 | 34 | 11 | M 10 |
| SYT 45 | 160 | 34 | 11 | M 10 |
| SYT 50 | 200 | 40 | 14 | M 12 |
| SYT 55 | 200 | 40 | 14 | M 12 |
| SYT 60 | 220 | 48 | 14 | M 12 |
| SYT 65 | 220 | 48 | 14 | M 12 |
| SYT 70 | 252 | 52 | 18 | M 16 |
| SYT 75 | 252 | 52 | 18 | M 16 |

Table 3

| Bolt size | Recommended tightening torque |
|-----------|-------------------------------|
| – | Nm |
| M 12 | 80 |
| M 16 | 200 |
| M 20 | 385 |
| M 24 | 656 |
| 1/2 UNC | 95 |
| 5/8 UNC | 185 |
| 3/4 UNC | 320 |
| 7/8 UNC | 515 |
| 1 UNC | 770 |

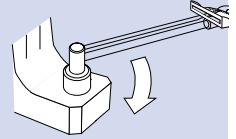

Tightening torques for attachment bolts of strength class 8.8

Position and size of four bolt holes

Table 4

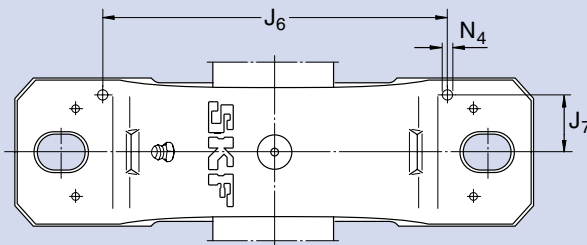

| Unit Basic designation | Dimensions | | N ₄ max |
|------------------------------|----------------|----------------|-----------------------|
| | J ₆ | J ₇ | |
| – | mm | | |
| SYT 35 | 135 | 23 | 6 |
| SYT 40 | 135 | 23 | 6 |
| SYT 45 | 135 | 23 | 6 |
| SYT 50 | 170 | 27 | 8 |
| SYT 55 | 172 | 27 | 8 |
| SYT 60 | 190 | 32 | 8 |
| SYT 65 | 190 | 32 | 8 |
| SYT 70 | 218 | 35 | 8 |
| SYT 75 | 218 | 35 | 8 |

Position and size of dowel pin holes

Pins

Where the load acts vertically towards the support surface, the ConCentra roller bearing units are adequately secured in position by the attachment bolts. If

- the direction of the load lies between 55° and 120° or if
- the load acts in parallel to the support surface and exceeds 5 % of the breaking load P_{180° , the units should be located against a stop or should be pinned to the support surface. Information on the lines of action of the loads as well as the breaking loads is given in **table 1** on **page 27**.

The position for holes to take such pins is indicated on the housing foot. Details of the position and size of these holes are given in **table 4**.

The housing surface

The housings of ConCentra roller bearing units are painted blue. The layer of paint offers protection against rust as specified by category C2, ISO 12944-2:1998. This is adequate for the majority of applications.

The units can be repainted by the user if it is desired to have a uniform colour for the machine or plant. When repainting it should be remembered that

- the housing bore with its bearing should be covered at both sides, e.g. with discs cut from cardboard or plastic,
- the grease nipple should be replaced by a plug which protects the thread,
- the colour is resistant to normally used low-alkalinity washing chemicals; to avoid fretting effects on the surface when washing coloured castings, it is, however, always important to follow the instructions from the supplier of the washing chemicals, regarding concentration, temperature and time.

The label carrying the unit designation (→ **fig 3**, **page 15**) is covered with a thin transparent foil, which can be peeled off after repainting, leaving the designation clearly visible.

Sealing

ConCentra roller bearing units are used in a large variety of applications so that demands can vary widely. To make the units suitable under extremely dirty conditions as well as under normal conditions but where circumferential speeds are high, these SKF units are available with a choice of contacting and non-contacting seals:

- double-lip seals (→ **fig 4**), no designation suffix, or
- labyrinth seals (→ **fig 5**), designation suffix TL.

The properties of these seals are described briefly in the following.

When selecting the seal the most important points to consider are

- the environmental conditions,
- the circumferential speed and
- the operating temperature.

If the operating temperature is particularly low or high, a check should be made that the operating temperature range of the standard grease is suitable.

Double-lip seals

The double-lip seal (→ **fig 4**) is a contacting seal. It consists of a double-lip nitrile rubber (NBR) seal vulcanised on to a pressed steel shell.

The steel shell sits firmly in the housing bore and provides static sealing. The externally directed dust lip forms a narrow gap with the cylindrical surface of the mounting rings and protects the

Double-lip seal

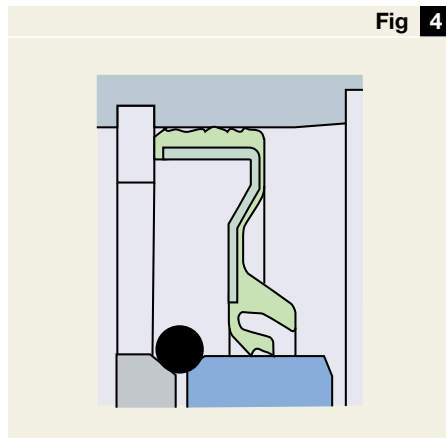

Fig 4

internal seal lips against abrasive material from the environment. The rubber lips prevent the entrance of dust and moisture and retain the grease; they do, however, allow excess grease to exit during relubrication.

The nitrile rubber has very good engineering properties which make it the most popular material for contacting seals. It has good resistance to many mineral oils and greases with a mineral oil base. It is also resistant to hot water. The operating temperature range lies between -50 and +100 °C, but brief periods of operation at temperatures up to +120 °C are possible.

The operational speed limits for the double-lip seal can be found in the product table on **page 29**.

Labyrinth seals

The labyrinth seal (→ **fig 5**) consists of three sheet steel rings. Two of these are mounted on the mounting rings, arranged at both sides of the bearing; they rotate with the shaft and act as flingers. The third ring is secured in the housing bore. A narrow sealing gap is formed between this ring and the other two rings.

When starting up or after relubrication of the ConCentra roller bearing units, excess grease may exit through the seal.

The labyrinth seals can be operated at the speeds quoted for the grease-lubricated spherical roller bearings (→ product table on **page 29**). There are no operating temperature limits except that imposed by the grease used in the unit.

Labyrinth seal

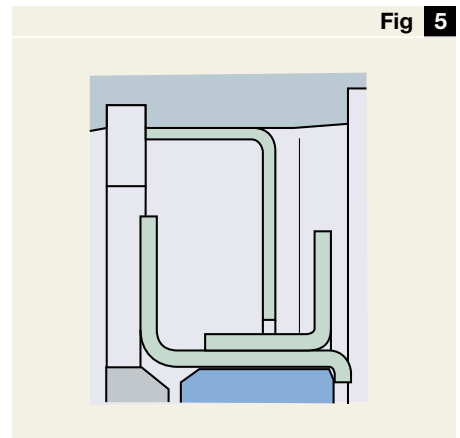

Fig 5

Lubrication

ConCentra roller bearing units are lubricated with SKF LGEP 2 grease before leaving the factory. The quantity of grease fills some 30 to 50 % of the free space in the housing. The LGEP 2 grease is a high-quality lithium thickener grease with a mineral base oil and it contains EP additives. The grease is characterised by:

- little wear under difficult operating conditions;
- good lubricating conditions under heavy loads and at low speeds;
- excellent ageing resistance;
- excellent water resistance;
- very good rust inhibiting properties.

It also fulfils demands for very smooth running.

ConCentra roller bearing units are equipped with a grease nipple AH 1/8-27 PTF as standard. This opens over the annular groove with its three lubrication holes in the outer ring of the bearing so that the bearing can be relubricated. The threaded hole for the nipple has a 1/8-27 NPSF thread which also permits the use of grease nipples with R 1/8, KR 1/8 and M10×1 threads.

The following accessories can be supplied to specific order:

- grease nipple M1 G 1/8 (→ fig 1) and
- nipple connection LAPN 1/8 (→ fig 2).

Replacement of the standard grease nipple AH 1/8-27 PTF with the nipple M1 G 1/8 must be made by the user.

The nipple connection LAPN 1/8 allows the easy installation of components having a thread G 1/4.

Relubrication

The ConCentra roller bearing units should be relubricated with a similar type of grease, i.e. SKF LGEP 2. The appropriate quantities are given in the product tables.

Before relubricating, the grease nipple and its immediate vicinity should be carefully cleaned. The use of high pressure cleaning equipment should be avoided.

When relubricating the grease should be supplied slowly as the bearing rotates. Excessive pressure should be avoided as otherwise the seals may be damaged.

The SKF grease gun 1077600 (→ fig 3) is most suitable for use with ConCentra roller bearing units. It is supplied with a 175 mm extension tube with automatic grip. A 500 mm long pressure tube 1077601 is available as an accessory. The SKF grease gun

- can be used for grease cartridges as well as “loose” grease,
- has a robust design, and
- is easy to use.

Grease gun 1077600



Fig 3

Grease nipple
M1 G 1/8Nipple connection
LAPN 1/8

To accurately measure the grease quantity, a grease metering unit LAGM 1000 can also be supplied by SKF. The unit can easily be attached to the SKF grease gun 1077600 (→ fig 4).

Grease metering unit LAGM 1000



Fig 4

Relubrication intervals

The relubrication intervals t_f for bearings on horizontal shafts under normal and clean conditions can be obtained from **diagram 1** as function of

- the speed factor A
where
 $A = n \times d_m$
n = rotational speed, r/min
 d_m = bearing mean diameter (→ **table 1**), mm
- the bearing factor b_f
depending on the load conditions
= 2 when $F_a/F_r \leq e$
= 6 when $F_a/F_r > e$
where e is the limiting value (→ **product tables**)
- the load ratio C/P

The relubrication interval t_f is an estimated value, valid for an operating temperature of 70 °C, for example:

Bearing mean diameter

Table 1

| ConCentra roller bearing units | | Bearing mean diameter |
|--------------------------------|------------|-----------------------|
| Size codes | | d_m (mm) |
| metric shaft | inch shaft | |
| 35 | – | 53,5 |
| 40 | 1.7/16 | 60 |
| – | 1.1/2 | 60 |
| 45 | 1.11/16 | 65 |
| – | 1.3/4 | 65 |
| 50 | 1.15/16 | 70 |
| – | 2 | 70 |
| 55 | 2.3/16 | 77,5 |
| 60 | – | 85 |
| 65 | 2.7/16 | 92,5 |
| – | 2.1/2 | 92,5 |
| 70 | – | 97,5 |
| 75 | 2.11/16 | 102,5 |
| – | 2.3/4 | 102,5 |
| – | 2.15/16 | 102,5 |
| – | 3 | 102,5 |
| – | 3.7/16 | 125 |
| – | 3.1/2 | 125 |
| – | 3.11/16 | 140 |
| – | 3.15/16 | 140 |
| – | 4 | 140 |

Diagram 1

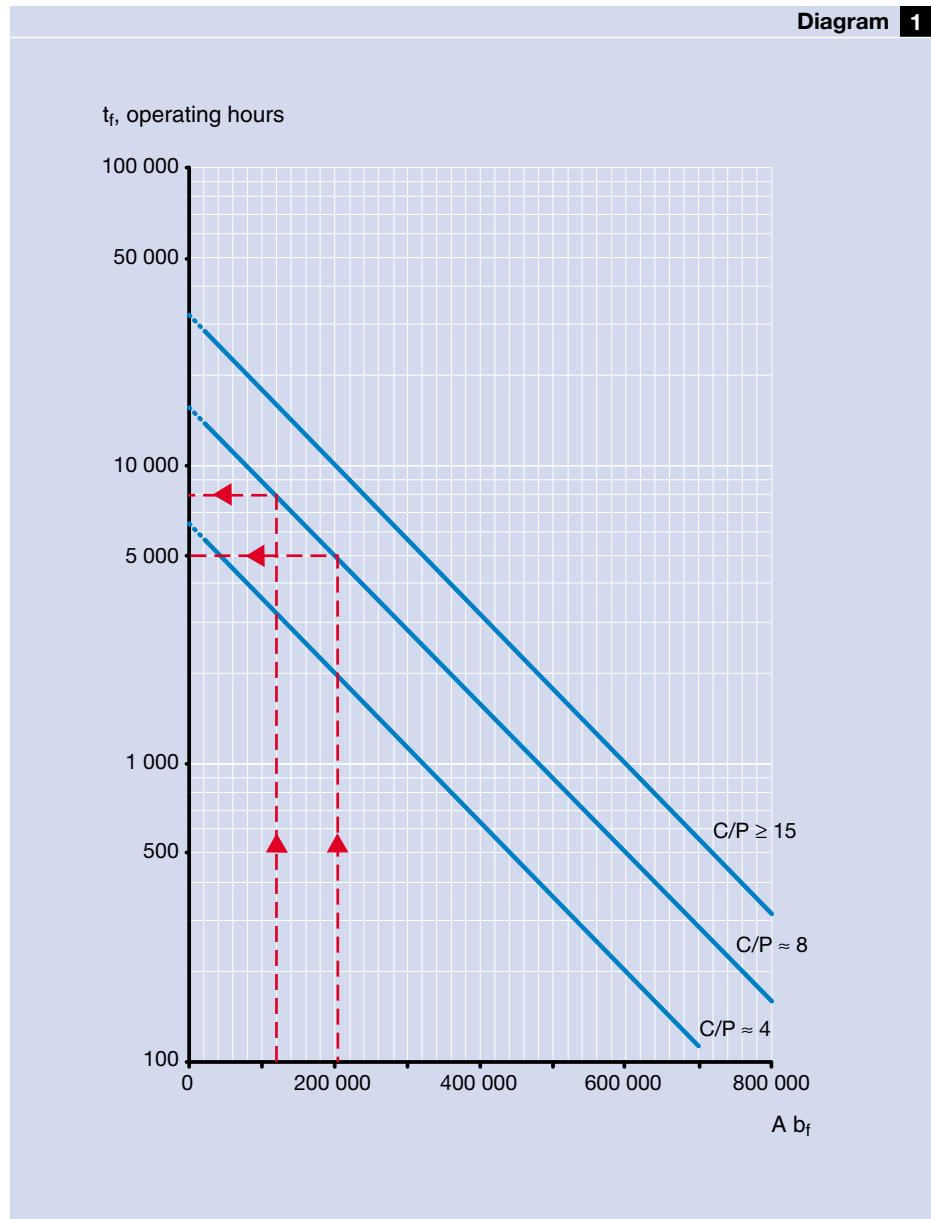

Relubrication intervals at operating temperatures of 70 °C

- ConCentra roller bearing unit SYT 40 L with bearing mean diameter 60 mm, rotational speed 1 000 r/min, C/P ≈ 8 and $F_a/F_r < e$ needs to be relubricated every 8 000 hours.
- ConCentra roller bearing unit SYT 75 L with bearing mean diameter 102,5 mm, operating speed 1 000 r/min, C/P ≈ 8 and $F_a/F_r < e$ needs to be relubricated every 5 000 hours.

For bearings on vertical shafts, the intervals obtained from **diagram 1** should be halved.

Trouble-Free Operation

Correctly chosen and correctly mounted ConCentra roller bearing units are highly reliable machine components – as long as adequate lubricant is available and contaminants and moisture cannot penetrate.

In spite of this it is still advisable to monitor the condition of ConCentra roller bearing units at regular intervals or continuously, in order to detect bearing damage in good time and also to be able to assess the extent and progress of the damage. It is then possible to plan the replacement of damaged units and avoid any unplanned stoppages. Routine checks of the noise and temperature should be made and the units optically inspected.

Condition monitoring using vibration analysis

The most reliable way of monitoring the condition of ConCentra roller bearing units is by vibration analysis (→ fig 1). This provides the best method of predicting bearing damage. The ConCentra roller bearing units can be fitted with vibration sensors, and three locations

are provided on the housings for this purpose.

SKF has a complete range of measuring equipment for condition monitoring, from light hand-held measuring pens to complex systems for permanent installation enabling the continuous monitoring of bearings and machines.

The range also includes the MARLIN™ system (→ fig 2). This machine reliability inspection system is designed for on site measurements and allows data from over 2 000 measuring points to be stored. The system can be used to analyse the vibration velocity enabling machine malfunction to be identified as well as the envelope curve of vibration acceleration to be produced which is used to analyse the bearing function.

Details of SKF condition monitoring equipment can be obtained from SKF and from authorised SKF distributors.

Recording vibration values



Fig 1

The MARLIN™ machine reliability inspection system



Fig 2

Mounting and dismounting

Tools

To mount or dismount ConCentra roller bearing units, the only tools required are

- a hexagonal key to tighten/loosen the grub screws in the mounting rings, and
- a spanner to tighten/loosen the attachment bolts.

A key 3L to ISO 2936:1996 is supplied with each unit together with a torque indicator (→ **fig 1**) and mounting instructions are packed with each unit. These should be followed.



Key with torque indicator



Double slot shims for ConCentra roller bearing units of series SYT

Double slot shims

To enable to adjust for the height differences between the support surfaces relative to the shaft, SKF can supply double slot shims (→ **fig 2**) for the ConCentra roller bearing units of series SYT. These shims, of series TMAS, are available in

- 4 different sizes, each having
- 4 different thicknesses.

They fit all SYT units of sizes 35 to 75 inclusive (→ **table 1**).

NB.

A grub screw of a ConCentra roller bearing unit should never be tightened until the unit is in position on the shaft, as otherwise

- the adapter sleeve may be deformed and/or
- the O-ring seal can be squashed.

The unit will then be impossible to mount.

Double slot shims for bearing units of series SYT

Table 1

| Unit Basic designation | Double slot shims Basic designation | Dimensions ¹⁾ | | |
|-------------------------------------------------|----------------------------------------|--------------------------|-----|----|
| | | A | B | C |
| – | – | mm | | |
| SYT 35 SYT 40 SYT 45 | TMAS D3 | 80 | 230 | 22 |
| SYT 50 SYT 55 | TMAS D4 | 90 | 274 | 26 |
| SYT 60 SYT 65 | TMAS D5 | 100 | 294 | 26 |
| SYT 70 SYT 75 | TMAS D6 | 110 | 328 | 30 |

¹⁾ All double slot shims are available in the following thicknesses: 0,05; 0,10; 0,25; 0,50 and 1,00 mm. A 0,25 mm thick shims TMAS D3 is designated TMAS D3-025

Mounting

A label marked “MOUNT. SIDE/ DISMOUNT. SIDE” shows the mounting and dismounting side, respectively, of the unit (→ **fig 3**, **page 15**).

1. Determine the positions of the locating and non-locating units. The locating unit should always be at the drive side.
2. Make sure that the base of the unit and the support surface are clean and free from burrs. For the support surface a flatness tolerance within tolerance grade IT7 is recommended. For less demanding applications IT8 may be satisfactory. Recommended max surface finish for the support surface is $R_a = 12,5 \mu\text{m}$. If the unit elevation is adjusted with shims these must cover the whole contact area between the unit and the support surface.
3. Make sure that the shaft is clean and free from burrs and check the dimensional and form accuracy of the shaft. For the shaft a diameter tolerance h9 and cylindricity tolerance grade IT5 are recommended. For less demanding applications h10 and IT7 may be satisfactory. Recommended max surface finish for the shaft is $R_a = 3,2 \mu\text{m}$. Lightly oil the shaft bearing seatings with low-viscosity oil.
4. Mount any components which are to be on the shaft between the bearing positions.
5. Push the units on to the shaft with the “dismounting side” leading. Leave 40 mm minimum space behind the unit to make dismounting possible.
6. Fasten the units to the support surface with the attachment bolts, but do not tighten.
7. Adjust the position of the units on the support surface if necessary.
8. Position the shaft axially in the units.

9. Lock the locating bearing (SYT .. F) on the shaft.
- 9a. This is done by tightening the grub screws in the “mounting side” ring using the hexagonal key. Follow the tightening pattern depending on the numbers of screws (→ **adjacent illustration**) and tighten 1/4 turn at the time.
- 9b. Tighten until the hexagonal key bows and comes at the same level as the mounted indicator. If a torque wrench is used the recommended tightening torque is 7,4 Nm.
10. Check the unit alignment. The maximum permissible misalignment of the shaft is $1,5^\circ$. Fully tighten the attachment bolts of the locating bearing unit. The recommended tightening torques are given in **table 3**, **page 16**.
11. Find the middle of the non-locating bearing seating in the housing (SYT .. L)
 - by supporting the shaft and
 - by pushing the unloaded bearing from one end position in the housing to the other.

If only thermal elongation of the shafts is expected it is recommended that the end position opposite to the locating bearing be chosen as the seating.
12. Lock the non-locating bearing on the shaft as under point 9.
13. Check the unit alignment. The maximum permissible misalignment of the shaft is $1,5^\circ$. Fully tighten the attachment bolts of the non-locating bearing unit. The recommended tightening torques are given in **table 3**, **page 16**.
14. If applicable, snap the end cover into the housing bore.

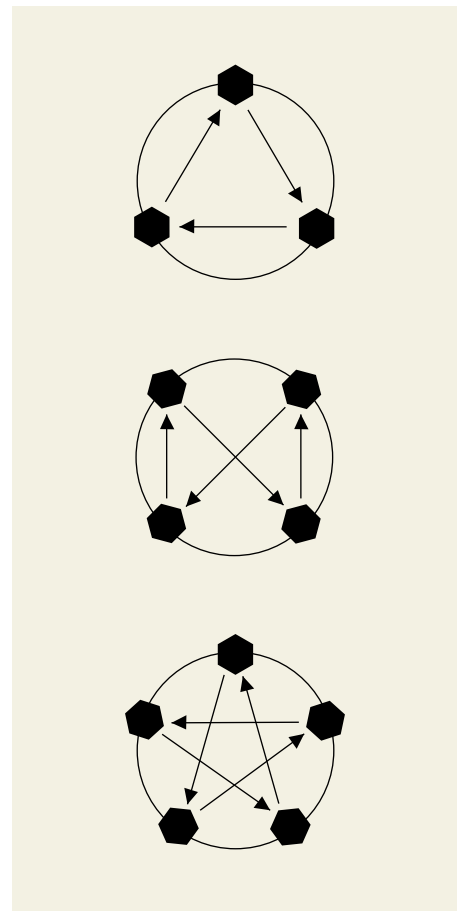

Tightening scheme for grub screws

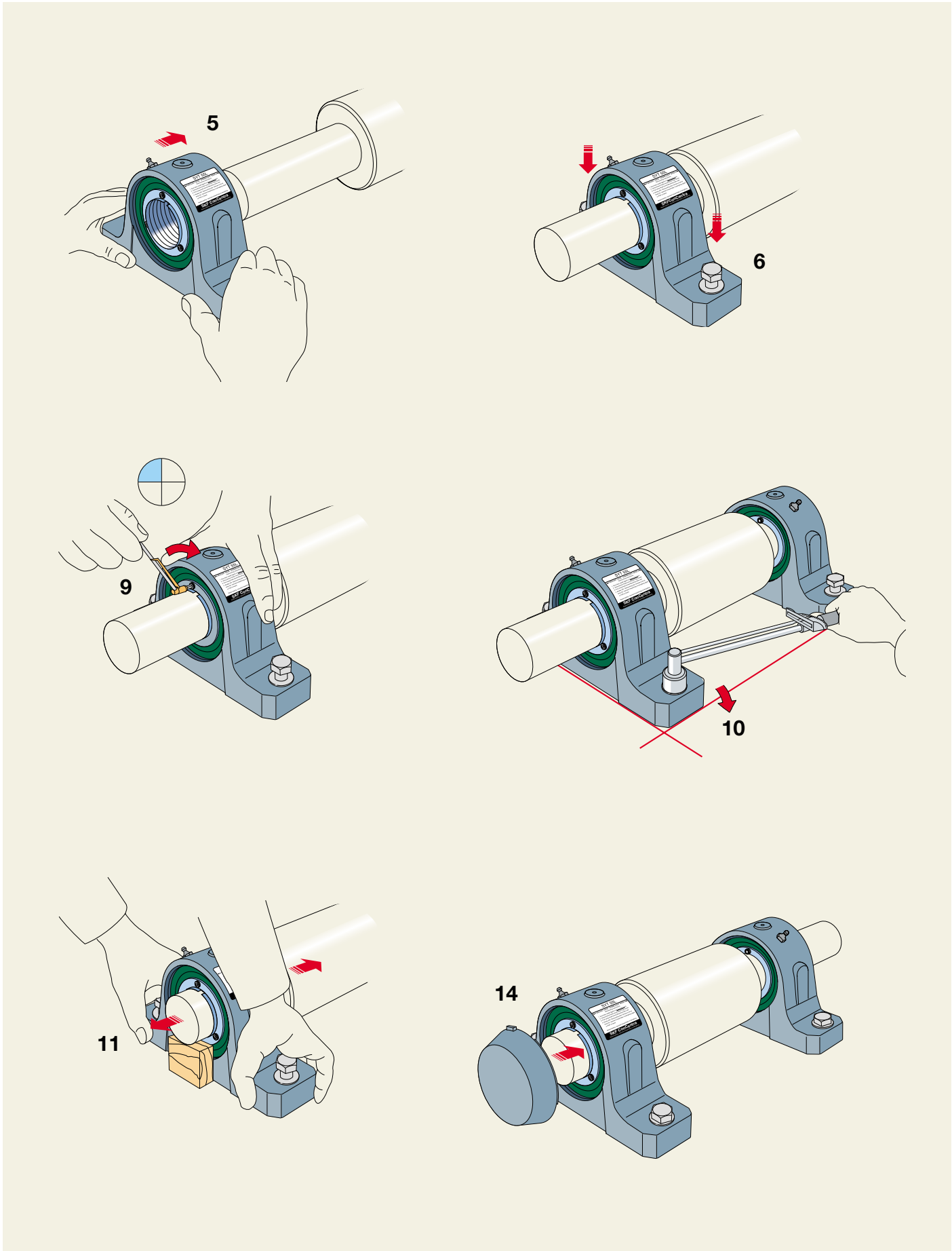

Dismounting

A label marked "MOUNT. SIDE/ DISMOUNT. SIDE" shows the mounting and dismounting side, respectively, of the unit (→ **fig 3**, **page 15**).

1. Clean the bearing position and all the internal hexagons of the grub screws. Remove the end cover (if any).
2. Remove any rust or damage over which the bearing unit is to be withdrawn.
3. Support the shaft with its components.
4. Loosen the attachment bolts.
5. Loosen the grub screws in the "mounting side" ring 3 or 4 turns.
6. Tighten the two grub screws in the "dismounting side" ring alternately by 1/4 of a turn until a noticeable "POP" is heard or felt. If no "POP" is heard or felt, continue to tighten the dismounting screws until the long end of the hexagonal wrench bows as maximum approx. 20 mm. If still no "POP" is heard or felt please follow the instructions given under the heading "Warning".
7. Loosen the grub screws in the "dismounting side" ring again by 3 or 4 turns.
8. Remove the attachment bolts.
9. Withdraw the unit from the shaft.
10. If the application permits, it is recommended to remove all the attachment bolts and to lift out the complete arrangement of shaft with ConCentra roller bearing units and other components. Then proceed as described under points 5 to 9.

Warning

On no account should the grub screws in the "dismounting side" ring be further tightened if the bearing and sleeve do not come free.

In such a case the following procedure should be followed.

- a The grub screws in the "dismounting side" ring should be loosened again by 3 or 4 turns.
- b Then the grub screws in the "mounting side" ring should be tightened until the long arm of the hexagonal key starts to bend noticeably.
- c The procedure described under points 5 and 6 should then be repeated.

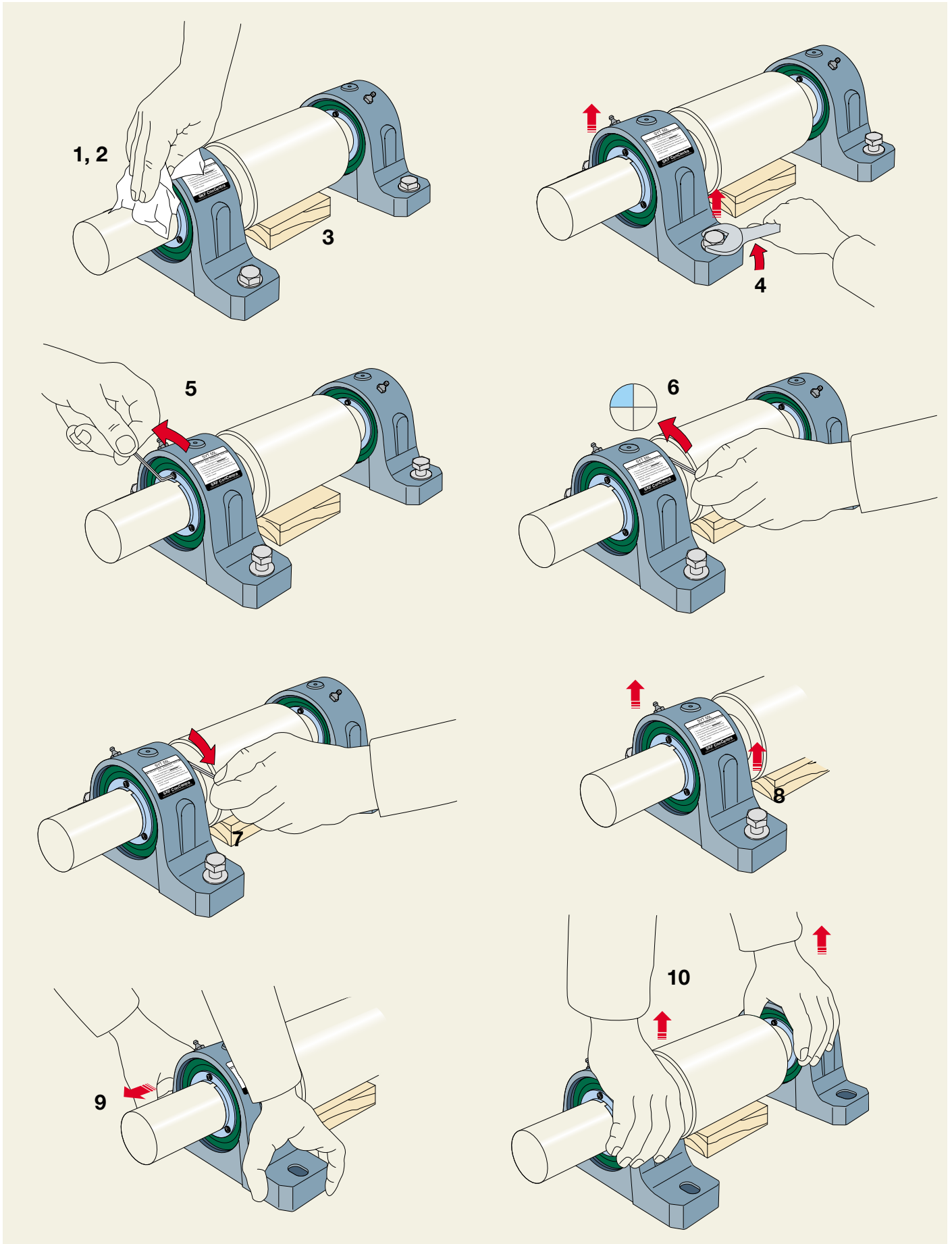

General product data

Dimensions

ConCentra roller bearing units of series SYT have dimensions that conform to ISO 113-2:1999, plummer block housing series 5 and are thus interchangeable with other housings to the same standard.

Internal clearance

ConCentra roller bearing units are supplied with pre-adjusted C3 radial internal bearing clearance for a tapered bore. The size and number of mounting set screws have been chosen to obtain the correct internal clearance when the unit is properly mounted.

Misalignment

ConCentra roller bearing units can accommodate angular misalignments of up to 1,5 degrees between the bearing positions.

Axial displaceability

The permissible axial displacement from the central position for non-locating ConCentra roller bearing units is min 1,1 mm and from the end position min 2,2 mm.

Minimum load

In order to provide satisfactory operation, spherical roller bearings in ConCentra roller bearing units must always be subjected to a given minimum load, especially if they are to operate at high speeds or are subjected to high accelerations or rapid changes in the direction of load. Under such conditions the inertia forces of the rollers and cages and the friction in the lubricant can have a detrimental influence on rolling conditions in the bearing arrangement and may cause damaging sliding movements to occur between the rollers and raceways.

The requisite minimum load to be applied can be estimated using

$$P_{0m} = 0,01 C_0$$

where

P_{0m} = minimum equivalent static load, kN

C_0 = basic static load rating, kN

When starting up at low temperatures or when the lubricant is highly viscous, even greater loads may be required. The weights of the components supported by the bearing, together with external forces, often exceed the requisite minimum load. If this is not the case, the bearing must be subjected to an additional radial load, e.g. by increasing belt tension or idling torque or by the similar means.

Speeds

The speeds at which ConCentra roller bearing units can be operated depend on the seal design. Guideline values are given in the product tables.

The (thermal) reference speed listed in the product tables represent a reference value that is to be used to determine the permissible operational speed of the bearing subjected to a certain load and running with LGEP 2 grease. Please refer to the SKF General Catalogue, section "Speeds and vibration". The values of the reference speed listed are in according with ISO 15312.

For bearings with double lip seals, the speed is limited by the seal friction.

Load carrying ability of the housings

ConCentra roller bearing units are designed for loads acting vertically towards the support surface.

Guideline values for the breaking load P for housings of series SYT are given in **table 1**. Using these values and a safety factor which depends on the operating conditions and reliability requirements the permissible load can be determined for the housing. In general engineering a safety factor of 6 is often used.

In this connection it is important that the attachment bolts are properly tightened. When loads act at an angle in excess of 90° the bolts must be equally firmly tightened.

The guideline values for spheroidal graphite cast iron housings can be obtained by multiplying the breaking loads given in **table 1** by a factor of 1,8.

The holding power of a ConCentra roller bearing unit depends on the friction between the shaft and the locking device. When correctly mounted the locking device gives the ConCentra roller bearing unit a holding power of approximately 15 kN.

Designations

The complete designation of a ConCentra roller bearing unit consists of

- the housing series identification,
- the size identification, i.e. the shaft diameter in mm, uncoded, and
- supplementary designations identifying design, seal, housing material and other features.

The designation scheme shown in **table 2** explains the significance of the various parts of the designation in the order in which they appear.

Table 1

| Unit Basic designation | Breaking loads for housings of grey cast iron | | | | |
|------------------------------|--------------------------------------------------|------------------|-------------------|-------------------|-------------------|
| | P _{55°} | P _{90°} | P _{120°} | P _{150°} | P _{180°} |
| – | kN | | | | |
| SYT 35 | 250 | 150 | 95 | 85 | 105 |
| SYT 40 | 265 | 160 | 100 | 90 | 110 |
| SYT 45 | 280 | 170 | 110 | 100 | 115 |
| SYT 50 | 330 | 200 | 130 | 115 | 140 |
| SYT 55 | 350 | 210 | 140 | 120 | 150 |
| SYT 60 | 365 | 220 | 150 | 130 | 170 |
| SYT 65 | 380 | 230 | 155 | 140 | 210 |
| SYT 70 | 400 | 240 | 160 | 145 | 215 |
| SYT 75 | 415 | 250 | 165 | 150 | 220 |

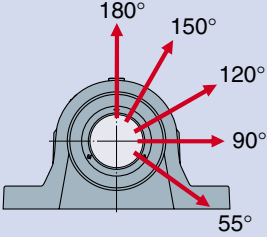

Breaking loads for ConCentra roller bearing units of series SYT

Designation scheme

Table 2

| | | | | | | | |
|----------------------------|------------------------------------------------------|--|------------|--|-----------|----------|-----------|
| Example | SYT 45 LTS | | SYT | | 45 | L | TS |
| Variants | | | | | | | |
| – | Two holes for attachment bolts | | | | | | |
| F | Four holes for attachment bolts | | | | | | |
| Basic designation | | | | | | | |
| SYT | Plummer block unit housing, series 5 to ISO 113:1999 | | | | | | |
| Housing material | | | | | | | |
| – | Grey cast iron | | | | | | |
| D | Spheroidal graphite cast iron | | | | | | |
| Size | | | | | | | |
| 35 | 35 mm bore diameter | | | | | | |
| to | | | | | | | |
| 75 | 75 mm bore diameter | | | | | | |
| Type of arrangement | | | | | | | |
| F | Locating unit | | | | | | |
| L | Non-locating unit | | | | | | |
| Seals | | | | | | | |
| – | Double-lip seals | | | | | | |
| TS | Labyrinth seals | | | | | | |

**ConCentra roller bearing units
for metric shafts
d_a 35 – 75 mm**

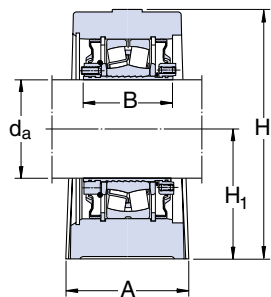

Non-locating bearing unit
SYT .. L

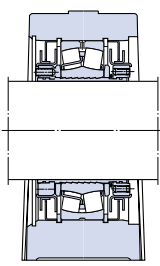

Locating bearing unit
SYT .. FTS

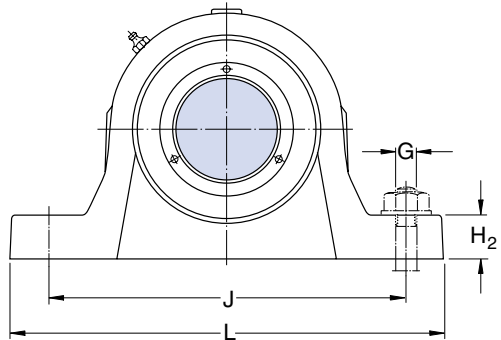

| Shaft diameter d _a | Bearing unit Dimensions | | | | H ₂ | J | L | N | N ₁ | G | Mass kg | Designations ¹⁾ | | |
|----------------------------------|-------------------------|------|-----|----------------|----------------|-----|-----|----|----------------|----|------------|-----------------------------------------|---------------------------|--|
| | A | B | H | H ₁ | | | | | | | | Non-locating unit with double-lip seals | unit with labyrinth seals | |
| mm | mm | | | | | | | | | | | kg | - | |
| 35 | 60 | 59,5 | 110 | 60 | 25 | 170 | 205 | 20 | 15 | 12 | 3,40 | SYT 35 L | SYT 35 LTS | |
| 40 | 60 | 59,5 | 114 | 60 | 25 | 170 | 205 | 20 | 15 | 12 | 3,50 | SYT 40 L | SYT 40 LTS | |
| 45 | 60 | 59,5 | 116 | 60 | 25 | 170 | 205 | 20 | 15 | 12 | 3,60 | SYT 45 L | SYT 45 LTS | |
| 50 | 70 | 59,5 | 129 | 70 | 28 | 210 | 255 | 24 | 18 | 16 | 4,80 | SYT 50 L | SYT 50 LTS | |
| 55 | 70 | 59,5 | 135 | 70 | 30 | 210 | 255 | 24 | 18 | 16 | 5,40 | SYT 55 L | SYT 55 LTS | |
| 60 | 80 | 65,5 | 150 | 80 | 30 | 230 | 275 | 24 | 18 | 16 | 7,00 | SYT 60 L | SYT 60 LTS | |
| 65 | 80 | 65,5 | 157 | 80 | 30 | 230 | 280 | 24 | 18 | 16 | 8,00 | SYT 65 L | SYT 65 LTS | |
| 70 | 90 | 65,5 | 177 | 95 | 32 | 260 | 315 | 28 | 22 | 20 | 10,5 | SYT 70 L | SYT 70 LTS | |
| 75 | 90 | 65,5 | 182 | 95 | 32 | 260 | 320 | 28 | 22 | 20 | 11,5 | SYT 75 L | SYT 75 LTS | |

All ConCentra units have SKF Explorer bearings

¹⁾ Locating bearing units are identified by the suffix F instead of L, e.g. SYT 35 F or SYT 35 FTS

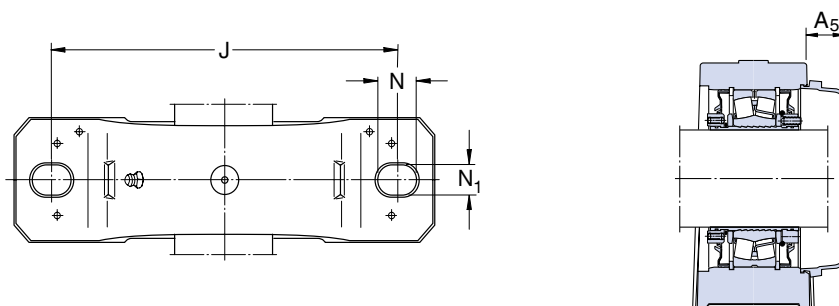

| Unit Basic designation | Bearing Basic designation | Basic load ratings | | Fatigue load limit P_u | Calculation factors | | | | Speed ratings | | Grease quantity Relubrication | Appropriate end cover | |
|---------------------------|------------------------------|--------------------|-----------------|-----------------------------|---------------------|-------|-------|-------|------------------------------------|------------------------------------|----------------------------------|-----------------------|---------------------|
| | | dynamic C | static C_0 | | e | Y_1 | Y_2 | Y_0 | Double-lip seals Limiting speed | Labyrinth seals Reference speed | | Designation | Protrusion A_5 |
| – | – | kN | kN | – | – | – | – | – | r/min | g | – | mm | |
| SYT 35 | 22207 | 86,5 | 85 | 9,3 | 0,31 | 2,2 | 3,3 | 2,2 | 4 400 | 9 000 | 10 | ECY 207 | 22 |
| SYT 40 | 22208 | 96,5 | 90 | 9,8 | 0,28 | 2,4 | 3,6 | 2,5 | 4 000 | 8 000 | 10 | ECY 208 | 23,5 |
| SYT 45 | 22209 | 102 | 98 | 10,8 | 0,26 | 2,6 | 3,9 | 2,5 | 3 700 | 7 500 | 10 | ECY 209 | 23 |
| SYT 50 | 22210 | 104 | 108 | 11,8 | 0,24 | 2,8 | 4,2 | 2,8 | 3 500 | 7 000 | 10 | ECY 210 | 29,5 |
| SYT 55 | 22211 | 125 | 137 | 13,7 | 0,24 | 2,8 | 4,2 | 2,8 | 3 250 | 6 300 | 15 | ECY 211 | 34 |
| SYT 60 | 22212 | 156 | 166 | 18,6 | 0,24 | 2,8 | 4,2 | 2,8 | 3 000 | 5 600 | 15 | ECY 212 | 35,5 |
| SYT 65 | 22213 | 193 | 216 | 24 | 0,24 | 2,8 | 4,2 | 2,8 | 2 900 | 5 300 | 20 | ECY 213 | 35,5 |
| SYT 70 | 22214 | 208 | 228 | 25,5 | 0,22 | 3 | 4,6 | 2,8 | 2 650 | 5 000 | 20 | ECY 214 | 38,5 |
| SYT 75 | 22215 | 212 | 240 | 26,5 | 0,22 | 3 | 4,6 | 2,8 | 2 600 | 4 800 | 20 | ECY 215 | 38,5 |

Series for inch shafts

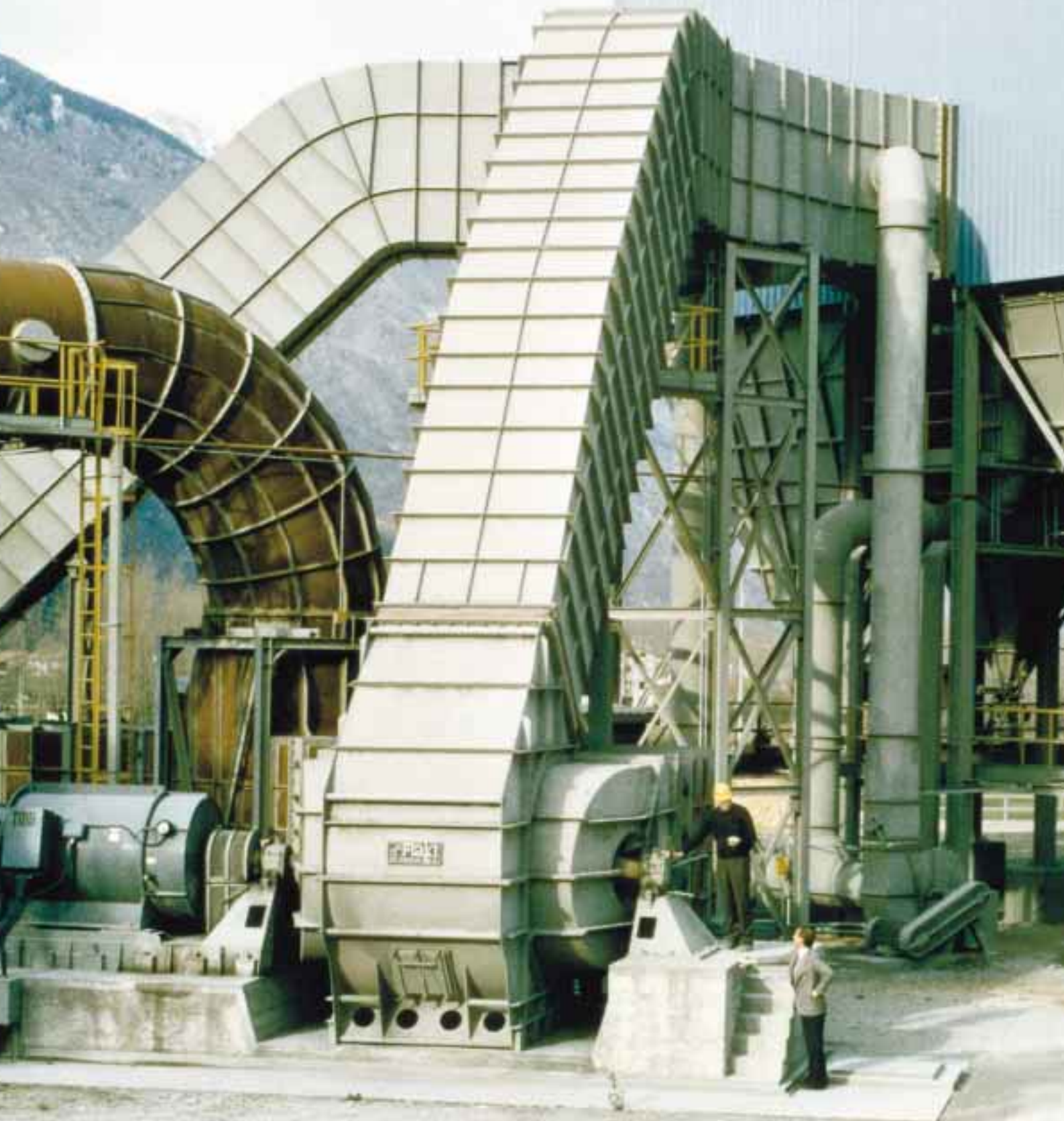

The standard range of ConCentra roller bearing units for metric shafts is complemented by several series and sizes of plummer block bearing units for inch-size shafts of diameter 1 7/16 to 4 in, inclusive. These differ slightly in their dimensions and designs. The range includes units in the

- SYR .. N series,
- SYE .. N series and
- FSYE .. N series.

based on the SYR, SYE and FSYE plummer block units which have been successful on the American market for many years. The most important technical data for these units for inch shafts will be found on **pages 32 to 39**.

Designations

The complete designation of a ConCentra roller bearing unit for inch shafts consists of:

- the housing series identification
- the size identification, i.e. the shaft diameter in inches, uncoded, and
- supplementary designations identifying design, seal and other features.

The designation scheme shown in **table 1** explains the significance of the various parts of the designation in the order in which they appear.

Table 1

| Example | FSYE 2.7/16 NH-118 | | | | |
|----------------------------|------------------------------------------------|-----|--------|----|------|
| | F | SYE | 2.7/16 | NH | -118 |
| Variants | | | | | |
| - | Two holes for attachment bolts | | | | |
| F | Four holes for attachment bolts | | | | |
| Basic designation | | | | | |
| SYE | Plummer (pillow) block unit with cast housing | | | | |
| SYR | Plummer (pillow) block unit with cast housing | | | | |
| FYR | Flanged unit with round, flat back housing | | | | |
| FYE | Flanged unit with square, flat back housing | | | | |
| FYRP | Flanged unit with round spigot piloted housing | | | | |
| TBR | Take-up unit with cast housing | | | | |
| Size | | | | | |
| 1.7/16 | 1 7/16 in bore diameter | | | | |
| to | | | | | |
| 4 | 4 in bore diameter | | | | |
| Type of arrangement | | | | | |
| N | ConCentra design | | | | |
| H | Locating bearing unit | | | | |
| Y | Closed end (end cover supplied) | | | | |
| Seals, others | | | | | |
| - | TriGard seals | | | | |
| -118 | Labyrinth seals | | | | |

Designation scheme



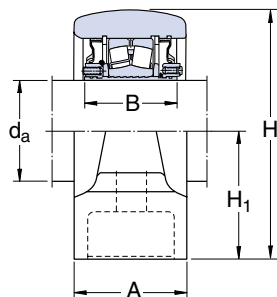

| Shaft diameter d_a | Bearing unit Dimensions | | | H_1 | H_2 | J | L | N | N_1 | G | Mass | Designation ¹⁾ Non-locating unit with TriGard contact seals |
|---------------------------------|-------------------------|-----------------|------------------|---------------|----------------|----------------|------------------|----------------|-------------|-----|--------------|---------------------------------------------------------------------------------|
| | A | B | H | | | | | | | | | |
| in/mm | in/mm | | | | | | | | | | lb/kg | - |
| 1 7/16 36,512 | 2 1/16 52,4 | 2 11/32 59,5 | 3 7/8 98,4 | 1 7/8 47,6 | 1 3/16 30,2 | 5 127 | 6 7/8 174,6 | 15/16 23,8 | 5/8 15,9 | 1/2 | 7.00 3,18 | SYR 1.7/16 N |
| 1 1/2 38,100 | 2 1/16 52,4 | 2 11/32 59,5 | 3 7/8 98,4 | 1 7/8 47,6 | 1 3/16 30,2 | 5 127 | 6 7/8 174,6 | 15/16 23,8 | 5/8 15,9 | 1/2 | 7.00 3,18 | SYR 1.1/2 N |
| 1 11/16 42,862 | 2 1/16 52,4 | 2 11/32 59,5 | 4 1/4 108 | 2 1/8 54 | 1 5/16 33,3 | 5 1/2 139,7 | 7 3/8 187,3 | 1 25,4 | 5/8 15,9 | 1/2 | 8.00 3,62 | SYR 1.11/16 N |
| 1 3/4 44,450 | 2 1/16 52,4 | 2 11/32 59,5 | 4 1/4 108 | 2 1/8 54 | 1 5/16 33,3 | 5 1/2 139,7 | 7 3/8 187,3 | 1 25,4 | 5/8 15,9 | 1/2 | 8.00 3,62 | SYR 1.3/4 N |
| 1 15/16 49,212 | 2 1/16 52,4 | 2 11/32 59,5 | 4 9/16 115,9 | 2 1/4 57,2 | 1 3/8 34,9 | 6 1/4 158,8 | 8 3/8 212,7 | 1 1/16 27 | 3/4 19 | 5/8 | 9.20 4,17 | SYR 1.15/16 N |
| 2 50,800 | 2 1/16 52,4 | 2 11/32 59,5 | 4 9/16 115,9 | 2 1/4 57,2 | 1 3/8 34,9 | 6 1/4 158,8 | 8 3/8 212,7 | 1 1/16 27 | 3/4 19 | 5/8 | 9.20 4,17 | SYR 2 N |
| 2 3/16 55,562 | 2 5/16 58,7 | 2 11/32 59,5 | 5 127 | 2 1/2 63,5 | 1 5/8 41,3 | 6 3/4 171,5 | 8 7/8 225,4 | 1 1/16 27 | 3/4 19 | 5/8 | 12.0 5,44 | SYR 2.3/16 N |
| 2 7/16 61,912 | 2 9/16 65,1 | 2 37/64 65,5 | 5 11/16 144,5 | 2 3/4 69,8 | 1 3/4 44,4 | 7 1/8 181 | 9 1/4 235 | 1 1/16 27 | 3/4 19 | 5/8 | 16.0 7,26 | SYR 2.7/16 N |
| 2 1/2 63,500 | 2 9/16 65,1 | 2 37/64 65,5 | 5 11/16 144,5 | 2 3/4 69,8 | 1 3/4 44,4 | 7 1/8 181 | 9 1/4 235 | 1 1/16 27 | 3/4 19 | 5/8 | 16.0 7,26 | SYR 2.1/2 N |
| 2 11/16 68,262 | 2 9/16 65,1 | 2 37/64 65,5 | 6 7/16 163,5 | 3 1/4 82,6 | 2 1/4 57,2 | 8 1/8 206,4 | 10 7/16 265,1 | 1 3/16 30,2 | 7/8 22,2 | 3/4 | 22.0 9,98 | SYR 2.11/16 N |
| 2 3/4 69,850 | 2 9/16 65,1 | 2 37/64 65,5 | 6 7/16 163,5 | 3 1/4 82,6 | 2 1/4 57,2 | 8 1/8 206,4 | 10 7/16 265,1 | 1 3/16 30,2 | 7/8 22,2 | 3/4 | 22.0 9,98 | SYR 2.3/4 N |
| 2 15/16 74,612 | 2 9/16 65,1 | 2 37/64 65,5 | 6 7/16 163,5 | 3 1/4 82,6 | 2 1/4 57,2 | 8 1/8 206,4 | 10 7/16 265,1 | 1 3/16 30,2 | 7/8 22,2 | 3/4 | 21.0 9,53 | SYR 2.15/16 N |
| 3 76,200 | 2 9/16 65,1 | 2 37/64 65,5 | 6 7/16 163,5 | 3 1/4 82,6 | 2 1/4 57,2 | 8 1/8 206,4 | 10 7/16 265,1 | 1 3/16 30,2 | 7/8 22,2 | 3/4 | 21.0 9,53 | SYR 3 N |
| 3 7/16 87,312 | 2 15/16 74,6 | 3 9/64 80 | 7 1/2 190,5 | 3 3/4 95,2 | 2 1/4 57,2 | 10 254 | 13 330,2 | 1 3/4 44,5 | 1 25,4 | 7/8 | 31.5 14,3 | SYR 3.7/16 N |
| 3 1/2 88,900 | 2 15/16 74,6 | 3 9/64 80 | 7 1/2 190,5 | 3 3/4 95,2 | 2 1/4 57,2 | 10 254 | 13 330,2 | 1 3/4 44,5 | 1 25,4 | 7/8 | 31.5 14,3 | SYR 3.1/2 N |

All ConCentra units have SKF Explorer bearings

With non-locating bearing units, the maximum possible axial displacement from the central position is 0,8 mm

¹⁾ Locating bearing units are identified by the suffix H, e.g. SYR 1.7/16 NH. Bearing units with labyrinth seals are identified by the suffix -118, e.g. SYR 1.7/16 N-118 or SYR 1.7/16 NH-118

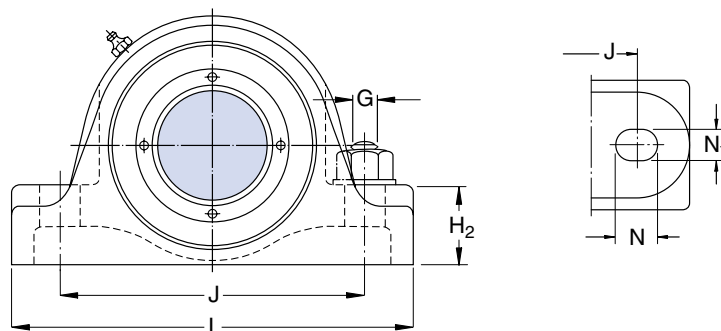

| Unit Designation | Bearing Basic designation | Basic load ratings dynamic C | Basic load ratings static C ₀ | Fatigue load limit P _u | Calculation factors | | | | Speed ratings | | Grease quantity Relubrication |
|----------------------|---------------------------|------------------------------|------------------------------------------|-----------------------------------|---------------------|----------------|----------------|----------------|------------------------------|---------------------------------|-------------------------------|
| | | | | | e | Y ₁ | Y ₂ | Y ₀ | TriGard seals Limiting speed | Labyrinth seals Reference speed | |
| - | - | lbs/kN | | lbs/kN | - | | | | r/min | | oz/g |
| SYR 1.7/16 N | 22208 | 21 600 96,5 | 20 000 90 | 2 200 9,8 | 0,28 | 2,4 | 3,6 | 2,5 | 2 500 | 8 000 | 0.35 10 |
| SYR 1.1/2 N | 22208 | 21 600 96,5 | 20 000 90 | 2 200 9,8 | 0,28 | 2,4 | 3,6 | 2,5 | 2 500 | 8 000 | 0.35 10 |
| SYR 1.11/16 N | 22209 | 22 800 102 | 22 000 98 | 2 400 10,8 | 0,26 | 2,6 | 3,9 | 2,5 | 2 300 | 7 500 | 0.35 10 |
| SYR 1.3/4 N | 22209 | 22 800 102 | 22 000 98 | 2 400 10,8 | 0,26 | 2,6 | 3,9 | 2,5 | 2 300 | 7 500 | 0.35 10 |
| SYR 1.15/16 N | 22210 | 23 300 104 | 24 200 108 | 2 650 11,8 | 0,24 | 2,8 | 4,2 | 2,8 | 2 150 | 7 000 | 0.35 10 |
| SYR 2 N | 22210 | 23 300 104 | 24 200 108 | 2 650 11,8 | 0,24 | 2,8 | 4,2 | 2,8 | 2 150 | 7 000 | 0.35 10 |
| SYR 2.3/16 N | 22211 | 28 100 125 | 30 700 137 | 3 070 13,7 | 0,24 | 2,8 | 4,2 | 2,8 | 2 000 | 6 300 | 0.53 15 |
| SYR 2.7/16 N | 22213 | 43 000 193 | 48 000 216 | 5 380 24 | 0,24 | 2,8 | 4,2 | 2,8 | 1 800 | 5 300 | 0.70 20 |
| SYR 2.1/2 N | 22213 | 43 000 193 | 48 000 216 | 5 380 24 | 0,24 | 2,8 | 4,2 | 2,8 | 1 800 | 5 300 | 0.70 20 |
| SYR 2.11/16 N | 22215 | 47 500 212 | 54 000 240 | 5 940 26,5 | 0,22 | 3 | 4,6 | 2,8 | 1 600 | 4 800 | 0.70 20 |
| SYR 2.3/4 N | 22215 | 47 500 212 | 54 000 240 | 5 940 26,5 | 0,22 | 3 | 4,6 | 2,8 | 1 600 | 4 800 | 0.70 20 |
| SYR 2.15/16 N | 22215 | 47 500 212 | 54 000 240 | 5 940 26,5 | 0,22 | 3 | 4,6 | 2,8 | 1 600 | 4 800 | 0.70 20 |
| SYR 3 N | 22215 | 47 500 212 | 54 000 240 | 5 940 26,5 | 0,22 | 3 | 4,6 | 2,8 | 1 600 | 4 800 | 0.70 200 |
| SYR 3.7/16 N | 22218 | 73 500 325 | 85 000 375 | 8 740 39 | 0,24 | 2,8 | 4,2 | 2,8 | 1 400 | 3 800 | 1.25 35 |
| SYR 3.1/2 N | 22218 | 73 500 325 | 85 000 375 | 8 740 39 | 0,24 | 2,8 | 4,2 | 2,8 | 1 400 | 3 800 | 1.25 35 |

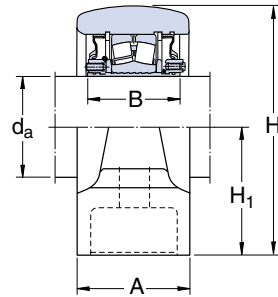

| Shaft diameter d_a | Bearing unit Dimensions | | | | | | | | | | Mass | Designation ¹⁾ Non-locating unit with TriGard contact seals |
|----------------------------------|-------------------------|--------------|-----------------|----------------|----------------|-----------------|---------------|-----------|----------------|---|--------------|---------------------------------------------------------------------------------|
| | A | B | H | H ₁ | H ₂ | J | L | N | N ₁ | G | | |
| in/mm | in/mm | | | | | | | | | | lb/kg | – |
| 3 11/16 93,662 | 3 5/16 84,1 | 3 9/64 80 | 8 7/16 214,3 | 4 1/4 108 | 2 1/2 63,5 | 10 7/8 276,2 | 14 1/4 362 | 2 50,8 | 1 1/8 28,6 | 1 | 44.5 20,2 | SYR 3.11/16 N |
| 3 15/16 100,012 | 3 15/16 84,1 | 3 9/64 80 | 8 7/16 214,3 | 4 1/4 108 | 2 1/2 63,5 | 10 7/8 276,2 | 14 1/4 362 | 2 50,8 | 1 1/8 28,6 | 1 | 43.5 19,7 | SYR 3.15/16 N |
| 4 101,600 | 3 15/16 84,1 | 3 9/64 80 | 8 7/16 214,3 | 4 1/4 108 | 2 1/2 63,5 | 10 7/8 276,2 | 14 1/4 362 | 2 50,8 | 1 1/8 28,6 | 1 | 43.5 19,7 | SYR 4 N |

All ConCentra units have SKF Explorer bearings

With non-locating bearing units, the maximum possible axial displacement from the central position is 0,8 mm

¹⁾ Locating bearing units are identified by the suffix H, e.g. SYR 3.11/16 NH. Bearing units with labyrinth seals are identified by the suffix -118, e.g. SYR 3.11/16 N-118 or SYR 3.11/16 NH-118

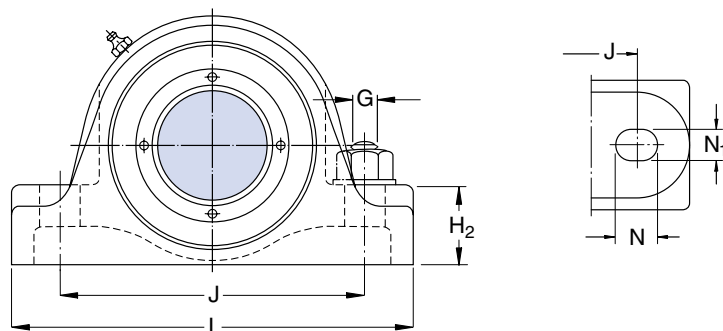

| Unit Designation | Bearing Basic designation | Basic load ratings | | Fatigue load limit P _u | Calculation factors | | | | Speed ratings | | Grease quantity Relubrication |
|----------------------|------------------------------|--------------------|--------------------------|-----------------------------------------|---------------------|----------------|----------------|----------------|---------------------------------------|------------------------------------------|-------------------------------------|
| | | dynamic C | static C ₀ | | e | Y ₁ | Y ₂ | Y ₀ | TriGard seals Limiting speed | Labyrinth seals Reference speed | |
| - | - | lbs/kN | lbs/kN | - | - | - | - | - | r/min | - | oz/g |
| SYR 3.11/16 N | 22220 | 95 000 425 | 110 000 490 | 10 980 49 | 0,24 | 2,8 | 4,2 | 2,8 | 1 250 | 3 400 | 1.60 45 |
| SYR 3.15/16 N | 22220 | 95 000 425 | 110 000 490 | 10 980 49 | 0,24 | 2,8 | 4,2 | 2,8 | 1 250 | 3 400 | 1.60 45 |
| SYR 4 N | 22220 | 95 000 425 | 110 000 490 | 10 980 49 | 0,24 | 2,8 | 4,2 | 2,8 | 1 250 | 3 400 | 1.60 45 |

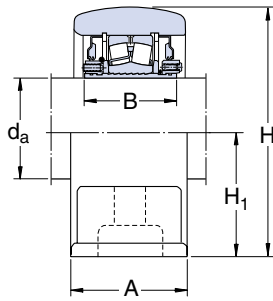

SYE

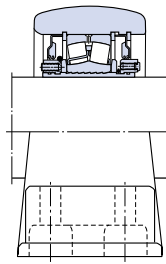

FSYE

| Shaft diameter d_a | Bearing unit Dimensions | | | | H ₂ | J | J ₁ | L | N | N ₁ | G | Mass | Designation ¹⁾ Non-locating unit with TriGard contact seals |
|---------------------------------|-------------------------|-----------------|------------------|----------------|----------------|----------------|----------------|-----------------|---------------|----------------|-----|--------------|---------------------------------------------------------------------------|
| | A | B | H | H ₁ | | | | | | | | | |
| in/mm | in/mm | | | | | | | | | | | lb/kg | – |
| 1 7/16 36,512 | 2 1/8 54 | 2 11/32 59,5 | 3 7/8 98,4 | 1 7/8 47,6 | 1 1/8 28,6 | 5 3/4 146 | – | 7 3/8 187,3 | 3/4 19 | 5/8 15,9 | 1/2 | 8.00 3,62 | SYE 1.7/16 N |
| 1 1/2 38,100 | 2 3/8 60,3 | 2 11/32 59,5 | 4 1/4 108 | 2 1/8 54 | 1 1/4 31,8 | 6 1/4 158,8 | – | 7 7/8 200 | 3/4 19 | 5/8 15,9 | 1/2 | 8.00 3,62 | SYE 1.1/2 N |
| 1 11/16 42,862 | 2 3/8 60,3 | 2 11/32 59,5 | 4 1/4 108 | 2 1/8 54 | 1 1/4 31,8 | 6 1/4 158,8 | – | 7 7/8 200 | 3/4 19 | 5/8 15,9 | 1/2 | 9.30 4,22 | SYE 1.11/16 N |
| 1 3/4 44,450 | 2 1/2 63,5 | 2 11/32 59,5 | 4 1/2 114,3 | 2 1/4 57,2 | 1 5/16 33,3 | 7 177,8 | – | 8 7/8 225,4 | 7/8 22,2 | 3/4 19 | 5/8 | 9.30 4,22 | SYE 1.3/4 N |
| 1 15/16 49,212 | 2 1/2 63,5 | 2 11/32 59,5 | 4 1/2 114,3 | 2 1/4 57,2 | 1 5/16 33,3 | 7 177,8 | – | 8 7/8 225,4 | 7/8 22,2 | 3/4 19 | 5/8 | 10.5 4,76 | SYE 1.15/16 N |
| 2 50,800 | 2 1/2 63,5 | 2 11/32 59,5 | 4 1/2 114,3 | 2 1/4 57,2 | 1 5/16 33,3 | 7 177,8 | – | 8 7/8 225,4 | 7/8 22,2 | 3/4 19 | 5/8 | 10.5 4,76 | SYE 2 N |
| 2 3/16 55,562 | 2 5/8 66,7 | 2 11/32 59,5 | 5 127 | 2 1/2 63,5 | 1 1/2 38,1 | 7 3/4 196,8 | – | 9 5/8 244,4 | 7/8 22,2 | 3/4 19 | 5/8 | 13.5 6,12 | SYE 2.3/16 N |
| 2 7/16 61,912 | 2 7/8 73 | 2 37/64 65,5 | 5 11/16 144,5 | 2 3/4 69,8 | 1 5/8 41,3 | 8 1/2 216 | – | 10 1/2 266,7 | 1 25,4 | 3/4 19 | 5/8 | 18.5 8,39 | SYE 2.7/16 N |
| | 3 1/2 88,9 | 2 37/64 65,5 | 5 11/16 144,5 | 2 3/4 69,8 | 1 5/8 41,3 | 8 1/2 216 | 1 7/8 47,6 | 10 1/2 266,7 | 1 25,4 | 3/4 19 | 5/8 | 19.0 8,62 | FSYE 2.7/16 N |
| 2 1/2 63,500 | 2 7/8 73 | 2 37/64 65,5 | 5 11/16 144,5 | 2 3/4 69,8 | 1 5/8 41,3 | 8 1/2 216 | – | 10 1/2 266,7 | 1 25,4 | 3/4 19 | 5/8 | 18.5 8,39 | SYE 2.1/2 N |
| | 3 1/2 88,9 | 2 37/64 65,5 | 5 11/16 144,5 | 2 3/4 69,8 | 1 5/8 41,3 | 8 1/2 216 | 1 7/8 47,6 | 10 1/2 266,7 | 1 25,4 | 3/4 19 | 5/8 | 19.0 8,62 | FSYE 2.1/2 N |
| 2 11/16 68,262 | 3 76,2 | 2 37/64 65,5 | 6 5/16 160,3 | 3 1/8 79,4 | 1 7/8 47,6 | 9 1/2 241,3 | – | 12 304,8 | 1 1/8 28,6 | 7/8 22,2 | 3/4 | 25.5 11,6 | SYE 2.11/16 N |
| | 4 101,6 | 2 37/64 65,5 | 6 5/16 160,3 | 3 1/8 79,4 | 1 7/8 47,6 | 9 1/2 241,3 | 2 1/8 54 | 12 304,8 | 1 1/8 28,6 | 3/4 19 | 5/8 | 25.5 11,6 | FSYE 2.11/16 N |
| 2 3/4 69,850 | 3 76,2 | 2 37/64 65,5 | 6 5/16 160,3 | 3 1/8 79,4 | 1 7/8 47,6 | 9 1/2 241,3 | – | 12 304,8 | 1 1/8 28,6 | 7/8 22,2 | 3/4 | 25.5 11,6 | SYE 2.3/4 N |
| | 4 101,6 | 2 37/64 65,5 | 6 5/16 160,3 | 3 1/8 79,4 | 1 7/8 47,6 | 9 1/2 241,3 | 2 1/8 54 | 12 304,8 | 1 1/8 28,6 | 3/4 19 | 5/8 | 25.5 11,6 | FSYE 2.3/4 N |

All ConCentra units have SKF Explorer bearings

With non-locating bearing units, the maximum possible axial displacement from the central position is 0,8 mm

¹⁾ Locating bearing units are identified by the suffix H, e.g. SYE 1.7/16 NH. Bearing units with labyrinth seals are identified by the suffix -118, e.g. SYE 1.7/16 N-118 or FSYE 2.7/16 NH-118

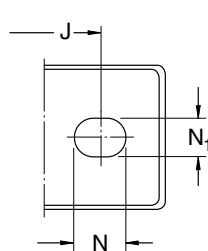
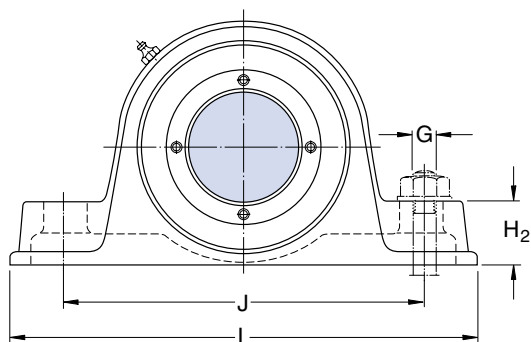

SYE

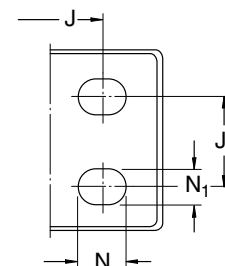

FSYE

| Unit Designation | Bearing Basic designation | Basic load ratings | | Fatigue load limit P_u | Calculation factors | | | | Speed ratings | | Grease quantity Relubrication |
|-----------------------|---------------------------|--------------------|---------------|--------------------------|---------------------|-------|-------|-------|------------------------------|---------------------------------|-------------------------------|
| | | dynamic C | static C_0 | | e | Y_1 | Y_2 | Y_0 | TriGard seals Limiting speed | Labyrinth seals Reference speed | |
| - | - | lbs/kN | lbs/kN | lbs/kN | - | - | - | - | r/min | - | oz/g |
| SYE 1.7/16 N | 22208 | 21 600 96,5 | 20 000 90 | 2 200 9,8 | 0,28 | 2,4 | 3,6 | 2,5 | 2 500 | 8 000 | 0,35 10 |
| SYE 1.1/2 N | 22208 | 21 600 96,5 | 20 000 90 | 2 200 9,8 | 0,28 | 2,4 | 3,6 | 2,5 | 2 500 | 8 000 | 0,35 10 |
| SYE 1.11/16 N | 22209 | 22 800 102 | 22 000 98 | 2 400 10,8 | 0,26 | 2,6 | 3,9 | 2,5 | 2 300 | 7 500 | 0,35 10 |
| SYE 1.3/4 N | 22209 | 22 800 102 | 22 000 98 | 2 400 10,8 | 0,26 | 2,6 | 3,9 | 2,5 | 2 300 | 7 500 | 0,35 10 |
| SYE 1.15/16 N | 22210 | 23 300 104 | 24 200 108 | 2 650 11,8 | 0,24 | 2,8 | 4,2 | 2,8 | 2 150 | 7 000 | 0,35 10 |
| SYE 2 N | 22210 | 23 300 104 | 24 200 108 | 2 650 11,8 | 0,24 | 2,8 | 4,2 | 2,8 | 2 150 | 7 000 | 0,35 10 |
| SYE 2.3/16 N | 22211 | 28 100 125 | 30 700 137 | 3 070 13,7 | 0,24 | 2,8 | 4,2 | 2,8 | 2 000 | 6 300 | 0,53 15 |
| SYE 2.7/16 N | 22213 | 43 000 193 | 48 000 216 | 5 380 24 | 0,24 | 2,8 | 4,2 | 2,8 | 1 800 | 5 300 | 0,70 20 |
| FSYE 2.7/16 N | 22213 | 43 000 193 | 48 000 216 | 5 380 24 | 0,24 | 2,8 | 4,2 | 2,8 | 1 800 | 5 300 | 0,70 20 |
| SYE 2.1/2 N | 22213 | 43 000 193 | 48 000 216 | 5 380 24 | 0,24 | 2,8 | 4,2 | 2,8 | 1 800 | 5 300 | 0,70 20 |
| FSYE 2.1/2 N | 22213 | 43 000 193 | 48 000 216 | 5 380 24 | 0,24 | 2,8 | 4,2 | 2,8 | 1 800 | 5 300 | 0,70 20 |
| SYE 2.11/16 N | 22215 | 47 500 212 | 54 000 240 | 5 940 26,5 | 0,22 | 3 | 4,6 | 2,8 | 1 600 | 4 800 | 0,70 20 |
| FSYE 2.11/16 N | 22215 | 47 500 212 | 54 000 240 | 5 940 26,5 | 0,22 | 3 | 4,6 | 2,8 | 1 600 | 4 800 | 0,70 20 |
| SYE 2.3/4 N | 22215 | 47 500 212 | 54 000 240 | 5 940 26,5 | 0,22 | 3 | 4,6 | 2,8 | 1 600 | 4 800 | 0,70 20 |
| FSYE 2.3/4 N | 22215 | 47 500 212 | 54 000 240 | 5 940 26,5 | 0,22 | 3 | 4,6 | 2,8 | 1 600 | 4 800 | 0,70 20 |

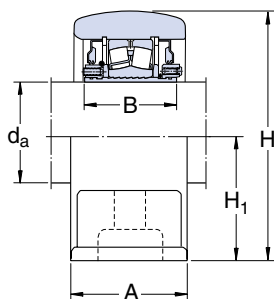

SYE

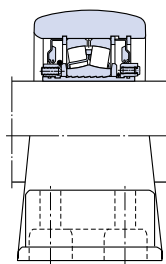

FSYE

| Shaft diameter d_a | Bearing unit Dimensions | | | H_1 | H_2 | J | J_1 | L | N | N_1 | G | Mass | Designation ¹⁾ Non-locating unit with TriGard contact seals |
|--------------------------------------------------------|-------------------------------|---------------------------------|--------------------------------|-------------------------------|--------------------------------|--------------------------------|-------------------------------|--------------------------------|--------------------------------|-----------------------------|-----------------------------|-------|---------------------------------------------------------------------------|
| | A | B | H | | | | | | | | | | |
| in/mm | in/mm | | | | | | | | | | | lb/kg | – |
| 2 ¹⁵/₁₆ 76,612 | 3 | 2 ³⁷ / ₆₄ | 6 ⁵ / ₁₆ | 3 ¹ / ₈ | 1 ⁷ / ₈ | 9 ¹ / ₂ | – | 12 | 1 ¹ / ₈ | ⁷ / ₈ | ³ / ₄ | 24.0 | SYE 2.15/16 N |
| | 76,2 | 65,5 | 160,3 | 79,4 | 47,6 | 241,3 | – | 304,8 | 28,6 | 22,2 | ³ / ₄ | 10,9 | |
| 3 76,200 | 4 | 2 ³⁷ / ₆₄ | 6 ⁵ / ₁₆ | 3 ¹ / ₈ | 1 ⁷ / ₈ | 9 ¹ / ₂ | 2 ¹ / ₈ | 12 | 1 ¹ / ₈ | ³ / ₄ | ⁵ / ₈ | 24.0 | FSYE 2.15/16 N |
| | 101,6 | 65,5 | 160,3 | 79,4 | 47,6 | 241,3 | 54 | 304,8 | 28,6 | 19 | ⁵ / ₈ | 10,9 | |
| 3 76,200 | 3 | 2 ³⁷ / ₆₄ | 6 ⁵ / ₁₆ | 3 ¹ / ₈ | 1 ⁷ / ₈ | 9 ¹ / ₂ | – | 12 | 1 ¹ / ₈ | ⁷ / ₈ | ³ / ₄ | 23.5 | SYE 3 N |
| | 76,2 | 65,5 | 160,3 | 79,4 | 47,6 | 241,3 | – | 304,8 | 28,6 | 22,2 | ³ / ₄ | 10,7 | |
| 3 ⁷/₁₆ 87,312 | 4 | 2 ³⁷ / ₆₄ | 6 ⁵ / ₁₆ | 3 ¹ / ₈ | 1 ⁷ / ₈ | 9 ¹ / ₂ | 2 ¹ / ₈ | 12 | 1 ¹ / ₈ | ³ / ₄ | ⁵ / ₈ | 24.0 | FSYE 3 N |
| | 101,6 | 65,5 | 160,3 | 79,4 | 47,6 | 241,3 | 54 | 304,8 | 28,6 | 19 | ⁵ / ₈ | 10,9 | |
| 3 ⁷/₁₆ 87,312 | 3 ⁵ / ₈ | 3 ⁹ / ₆₄ | 7 ¹ / ₂ | 3 ³ / ₄ | 2 ¹ / ₄ | 11 | – | 14 | 1 ⁵ / ₁₆ | 1 | ⁷ / ₈ | 35.5 | SYE 3.7/16 N |
| | 92,1 | 80 | 190,5 | 95,2 | 57,2 | 279,4 | – | 355,6 | 33,3 | 25,4 | ⁷ / ₈ | 16,1 | |
| 3 ¹/₂ 88,900 | 4 ¹ / ₂ | 3 ⁹ / ₆₄ | 7 ¹ / ₂ | 3 ³ / ₄ | 2 ¹ / ₄ | 11 | 2 ³ / ₈ | 14 | 1 ⁵ / ₁₆ | ⁷ / ₈ | ³ / ₄ | 36.5 | FSYE 3.7/16 N |
| | 114,3 | 80 | 190,5 | 95,2 | 57,2 | 279,4 | 60,3 | 355,6 | 33,3 | 22,2 | ³ / ₄ | 16,6 | |
| 3 ¹/₂ 88,900 | 3 ⁵ / ₈ | 3 ⁹ / ₆₄ | 7 ¹ / ₂ | 3 ³ / ₄ | 2 ¹ / ₄ | 11 | – | 14 | 1 ⁵ / ₁₆ | 1 | ⁷ / ₈ | 35.5 | SYE 3.1/2 N |
| | 92,1 | 80 | 190,5 | 95,2 | 57,2 | 279,4 | – | 355,6 | 33,3 | 25,4 | ⁷ / ₈ | 16,1 | |
| 3 ¹¹/₁₆ 93,662 | 4 ¹ / ₂ | 3 ⁹ / ₆₄ | 7 ¹ / ₂ | 3 ³ / ₄ | 2 ¹ / ₄ | 11 | 2 ³ / ₈ | 14 | 1 ⁵ / ₁₆ | ⁷ / ₈ | ³ / ₄ | 36.5 | FSYE 3.1/2 N |
| | 114,3 | 80 | 190,5 | 95,2 | 57,2 | 279,4 | 60,3 | 355,6 | 33,3 | 22,2 | ³ / ₄ | 16,6 | |
| 3 ¹¹/₁₆ 93,662 | 4 ¹ / ₂ | 3 ⁹ / ₆₄ | 8 ⁹ / ₁₆ | 4 ¹ / ₄ | 2 ⁷ / ₁₆ | 12 ¹ / ₂ | 2 ¹ / ₄ | 15 ¹ / ₄ | 1 ³ / ₈ | ⁷ / ₈ | ³ / ₄ | 50.5 | FSYE 3.11/16 N |
| | 114,3 | 80 | 217,5 | 108 | 61,9 | 317,5 | 57,2 | 387,4 | 34,9 | 22,2 | ³ / ₄ | 22,9 | |
| 3 ¹⁵/₁₆ 100,012 | 4 ¹ / ₂ | 3 ⁹ / ₆₄ | 8 ⁹ / ₁₆ | 4 ¹ / ₄ | 2 ⁷ / ₁₆ | 12 ¹ / ₂ | 2 ¹ / ₄ | 15 ¹ / ₄ | 1 ³ / ₈ | ⁷ / ₈ | ³ / ₄ | 49.5 | FSYE 3.15/16 N |
| | 114,3 | 80 | 217,5 | 108 | 61,9 | 317,5 | 57,2 | 387,4 | 34,9 | 22,2 | ³ / ₄ | 22,5 | |
| 4 101,600 | 4 ¹ / ₂ | 3 ⁹ / ₆₄ | 8 ⁹ / ₁₆ | 4 ¹ / ₄ | 2 ⁷ / ₁₆ | 12 ¹ / ₂ | 2 ¹ / ₄ | 15 ¹ / ₄ | 1 ³ / ₈ | ⁷ / ₈ | ³ / ₄ | 49.5 | FSYE 4 N |
| | 114,3 | 80 | 217,5 | 108 | 61,9 | 317,5 | 57,2 | 387,4 | 34,9 | 22,2 | ³ / ₄ | 22,5 | |

All ConCentra units have SKF Explorer bearings

With non-locating bearing units, the maximum possible axial displacement from the central position is 0,8 mm

¹⁾ Locating bearing units are identified by the suffix H, e.g. SYE 2.15/16 NH. Bearing units with labyrinth seals are identified by the suffix -118, e.g. SYE 2.15/16 N-118 or FSYE 2.15/16 NH-118

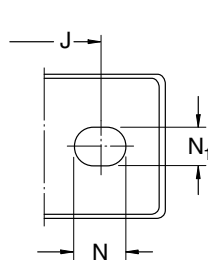
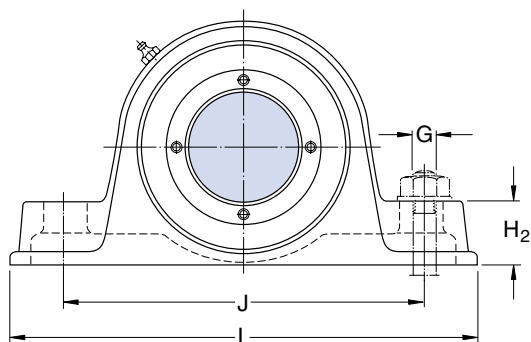

SYE

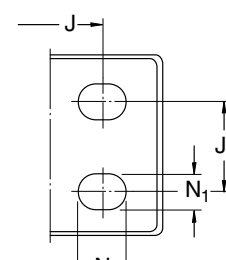

FSYE

| Unit Designation | Bearing Basic designation | Basic load ratings | | | Fatigue load limit P_u | Calculation factors | | | Speed ratings | | Grease quantity Relubrication |
|-----------------------|---------------------------|--------------------|----------------|---------------|--------------------------|---------------------|-------|-------|---------------|------------------------------|-------------------------------|
| | | dynamic C | static C_0 | | | e | Y_1 | Y_2 | Y_0 | TriGard seals Limiting speed | |
| - | - | lbs/kN | lbs/kN | lbs/kN | - | - | - | - | r/min | | oz/g |
| SYE 2.15/16 N | 22215 | 47 500 212 | 54 000 240 | 5 940 26,5 | 0,22 | 3 | 4,6 | 2,8 | 1 600 | 4 800 | 0.70 20 |
| FSYE 2.15/16 N | 22215 | 47 500 212 | 54 000 240 | 5 940 26,5 | 0,22 | 3 | 4,6 | 2,8 | 1 600 | 4 800 | 0.70 20 |
| SYE 3 N | 22215 | 47 500 212 | 54 000 240 | 5 940 26,5 | 0,22 | 3 | 4,6 | 2,8 | 1 600 | 4 800 | 0.70 20 |
| FSYE 3 N | 22215 | 47 500 212 | 54 000 240 | 5 940 26,5 | 0,22 | 3 | 4,6 | 2,8 | 1 600 | 4 800 | 0.70 20 |
| SYE 3.7/16 N | 22218 | 73 500 325 | 85 000 375 | 8 740 39 | 0,24 | 2,8 | 4,2 | 2,8 | 1 400 | 3 800 | 1.25 35 |
| FSYE 3.7/16 N | 22218 | 73 500 325 | 85 000 375 | 8 740 39 | 0,24 | 2,8 | 4,2 | 2,8 | 1 400 | 3 800 | 1.25 35 |
| SYE 3.1/2 N | 22218 | 73 500 325 | 85 000 375 | 8 740 39 | 0,24 | 2,8 | 4,2 | 2,8 | 1 400 | 3 800 | 1.25 35 |
| FSYE 3.1/2 N | 22218 | 73 500 325 | 85 000 375 | 8 740 39 | 0,24 | 2,8 | 4,2 | 2,8 | 1 400 | 3 800 | 1.25 35 |
| FSYE 3.11/16 N | 22220 | 95 000 425 | 110 000 490 | 10 980 49 | 0,24 | 2,8 | 4,2 | 2,8 | 1 250 | 3 400 | 1.60 45 |
| FSYE 3.15/16 N | 22220 | 95 000 425 | 110 000 490 | 10 980 49 | 0,24 | 2,8 | 4,2 | 2,8 | 1 250 | 3 400 | 1.60 45 |
| FSYE 4 N | 22220 | 95 000 425 | 110 000 490 | 10 980 49 | 0,24 | 2,8 | 4,2 | 2,8 | 1 250 | 3 400 | 1.60 45 |

Other SKF bearing units

Other roller bearing units

In addition to ConCentra roller bearing units, the following units (mounted bearings) are also available

- plummer block units in the SYR, SYE and FSYE series
- flanged units in the FYR and FYRP series
- take-up units in the TBR series.

The mounted bearings have been available on the American market for many years and have proved their good performance. They differ from the ConCentra roller bearing units in the design of the bearing and its attachment to the shaft. Instead of

the stepped sleeve, the bearings are secured on the shaft by a locking collar with two grub (set) screws which pass through holes in the bearing inner ring.

These units with locking collar are dimensionally interchangeable with similar units on the American market but have an appreciable advantage in that they incorporate SKF spherical roller bearings.

SKF units of series SYR can replace plummer block units of series P2B-SN 2000, ZA as well as P(E)-B22400 H; SYE units can replace series E, EP-B22400 H and ZEP; FSYE units with four holes for attachment bolts in the foot can replace series E, EP-B22400-FH and ZEP.



ConCentra ball bearing units

ConCentra ball bearing units are a completely new addition to the SKF assortment. Units are available for

- metric shafts in the diameter range 25 to 60 mm, inclusive, and
- inch-size shafts in the diameter range 1 to 2 ¹⁵/₁₆ in, also inclusive

The units are based on the SKF SY cast iron plummer block design, which makes the ConCentra units dimensionally interchangeable. They are recommended for bearing applications that operate at high speeds under moderate loads and provide:

- quiet running with minimum vibration,
- long operating periods,
- easy mounting and dismounting with no damage to the shaft
- minimal fretting corrosion

More detailed information on these ConCentra bearing units will be supplied on request.

Y-bearing units

Y-bearing units are ready-to-mount and ready-to-operate bearing units. Instead of the spherical roller bearings of ConCentra roller bearing units, they

incorporate Y-bearings based on deep groove ball bearings in the 62 series.

SKF Y-bearing units are available in a variety of designs. The housings are available as

- plummer block housings,
- flanged housings and
- take-up housings.

All these housing designs are available in grey cast iron, the plummer block and flanged designs are also produced in pressed steel and polyamide versions.

There are three different means of attachment to the shaft. Thus, the inner ring which is extended at one or both sides has

- two grub screws, or
- an eccentric ring with one grub screw, or
- a tapered bore for adapter sleeve mounting.

The choice is even wider than indicated above as there is also a choice of

- three seal variants,
- two material variants, and
- several different grease fills.

More information about

- collar mounted roller bearing units (→ **catalogue 100-700**)
- ConCentra ball bearing units (→ **brochure 5107**)
- Y-bearing units (→ **catalogue 5001**)



SKF - The knowledge engineering company

The business of the SKF Group consists of the design, manufacture and marketing of the world's leading brand of rolling bearings, with a global leadership position in complementary products such as radial seals. SKF also holds an increasingly important position in the market for linear motion products, high precision aerospace bearings, machine tool spindles, plant maintenance services and is an established producer of high-quality bearing steel.

The SKF Group maintains specialized businesses to meet the needs of the global marketplace. SKF supports specific market segments with ongoing research and development efforts that have led to a growing number of innovations, new standards and new products.

SKF Group has global ISO 14001 environmental certification. Individual divisions have been approved for quality certification in accordance with either ISO 9000 or appropriate industry specific standards.

Some 80 manufacturing sites worldwide and sales companies in 70 countries make SKF a truly international corporation. In addition, our 7 000 distributor and dealer partners around the world, e-business marketplace and global distribution system put SKF close to customers for the supply of both products and services. In essence, SKF solutions are available wherever and whenever our customers need them.

Overall, the SKF brand now stands for more than ever before. It stands for the knowledge engineering company ready to serve you with world-class product competences, intellectual resources and the vision to help you succeed.



Harnessing wind power

The growing industry of wind-generated electric power provides an environmentally compatible source of electricity. SKF is working closely with global industry leaders to develop efficient and trouble-free turbines, using SKF knowledge to provide highly specialized bearings and condition monitoring systems to extend equipment life in the extreme and often remote environments of wind farms.

Developing a cleaner cleaner

The electric motor and its bearings are the heart of many household appliances. SKF works closely with appliance manufacturers to improve their product's performance, cut costs and reduce weight. A recent



example produced a new generation of vacuum cleaners with substantially more suction. SKF's knowledge in small bearing technology is also applied to manufacturers of power tools and office equipment.



Delivering asset efficiency optimization

To optimize efficiency and boost productivity, many industrial facilities outsource some or all of their maintenance services to SKF, often with guaranteed performance contracts. Through the specialized capabilities and knowledge available from

SKF Reliability Systems, SKF provides a comprehensive range of asset efficiency services, from maintenance strategies and engineering assistance, to operator-driven reliability and machine maintenance programs.



Creating a new “cold remedy”

In the frigid winters of northern China, sub-zero temperatures can cause rail car wheel assemblies and their bearings to seize due to lubrication starvation. SKF created a new family of synthetic lubricants formulated to retain their lubrication viscosity even at these extreme bearing temperatures. SKF’s knowledge of lubricants and friction are unmatched throughout the world.



Planning for sustainable growth

By their very nature, bearings make a positive contribution to the natural environment. Reduced friction enables machinery to operate more efficiently, consume less power and require less lubrication. SKF is continually raising the performance bar, enabling new generations of high-efficiency products and equipment. With an eye to the future, SKF’s global policies and manufacturing techniques are planned and implemented to help protect and preserve the earth’s limited natural resources. We remain committed to sustainable, environmentally responsible growth.

Evolving by-wire technology

SKF has unique expertise and knowledge in fast growing by-wire technology, from fly-by-wire, to drive-by-wire, to work-by-wire. SKF pioneered practical fly-by-wire technology and is a close working partner with all aerospace industry leaders. As an example, virtually all aircraft of the Airbus design use SKF by-wire systems for cockpit flight control. SKF is also a leader in automotive drive-by-wire,

having jointly developed the revolutionary Filo and Novanta concept cars which employ SKF mechatronics for steering and braking. Further by-wire development has led SKF to produce an all-electric forklift truck which uses mechatronics rather than hydraulics for all controls.



Maintaining a 320 km/h R&D lab

In addition to SKF’s renowned research and development facilities in Europe and the United States, Formula One car racing provides a unique environment for SKF to push the limits of bearing technology. For over 50 years, SKF products, engineering and knowledge have helped make

Scuderia Ferrari a formidable force in F1 racing. (The average racing Ferrari utilizes more than 150 SKF components.) Lessons learned here are applied to the products we provide to automakers and the after-market worldwide.



® SKF is a registered trademark of the SKF Group.

™ MARLIN is a trademark of the SKF Group.

© Copyright SKF 2003

The contents of this publication are the copyright of the publisher and may not be reproduced (even extracts) unless permission is granted. Every care has been taken to ensure the accuracy of the information contained in this publication but no liability can be accepted for any loss or damage whether direct, indirect or consequential arising out of the use of the information contained herein.

Publication **5103 E** · October 2003

Printed in Sweden on environmentally friendly, chlorine-free paper (Multiart Silk) by Hyltebruks Tryckeri AB.

www.skf.com