

Split pillow blocks SDAF series including the extended range (inch dimensions)

Bearing types

- Spherical roller bearings
- CARB toroidal roller bearings

Bearing dimension series

- 22, 23 (SDAF)
- 30, 31, 32 (SDAF extended range)

Shaft diameter range

- 2 ¹⁵/₁₆ to 9 ⁹/₁₆ in. (SDAF)
- 9 in. and larger (SDAF extended range)

Typical shaft-bearing combinations

- Plain shaft with bearings on an adapter sleeve
- Stepped shafts with bearings on a cylindrical seat

Seals

- Labyrinth
- Contact
- Heavy-duty

Lubrication

- Grease
- Oil

Materials

- Grey cast iron
- Ductile iron (Spheroidal graphite cast iron)
- Cast steel

Mounting

- Four-bolt mounting

Compliance to standards

- Not standardized

All SDAF housings, which include the SDAF extended range, are heavy duty split pillow (plummer) block housings designed for tough operating conditions where heavy loads and shock loads require a housing that is exceptionally sturdy. All SDAF housings are made to order.

SDAF housings can accommodate bearings in the 22 and 23 dimension series for shaft diameters ranging from 2 ¹⁵/₁₆ to 9 ⁹/₁₆ inches. SDAF extended range housings can accommodate bearings in the 30, 31 and 32 dimension series for shaft diameters ranging from 8 ¹⁵/₁₆ to 20 inches and larger. Housings in the extended range are typically customized to meet the needs of a particular application.

Units of measurement

In this chapter only imperial units are used. To convert imperial units to metric units, refer to the conversion table on **page 10**.

Split pillow blocks SDAF series including the extended range (inch dimensions)

Designations	451	Mounting	470
Standard housing design	452	Condition Monitoring	470
Features and benefits	452	Ordering Information	470
Housing material	453	Product tables	
Housing variants and customization	453	9.1 SDAF pillow blocks with spherical roller bearings on an adapter sleeve (Series 225(00), 226(00))	472
Housing material	453	9.2 SDAF pillow blocks with spherical roller bearings on a cylindrical seat (Series 222(00), 223(00))	474
Paint, corrosion protection	453	9.3 SDAF extended range pillow blocks with spherical roller bearings on an adapter sleeve (Series 230(00) KA, 231(00) KA, 232(00) KA)	476
Sealing solutions	454	9.4 SDAF extended range pillow blocks with spherical roller bearings on a cylindrical seat (Series 230(00), 231(00), 232(00))	480
Labyrinth seals	454		
Labyrinth rings with an internal contact element	460		
Taconite heavy-duty seals	460		
Contact seals	461		
End plugs	461		
Special seals	462		
Design considerations	462		
Typical shaft-bearing combinations ...	462		
Locating and non-locating bearing positions	463		
Load carrying ability	463		
Operating temperature	466		
Operating speed	466		
Shaft specifications	466		
Attachment bolt recommendations ...	466		
Lubrication	467		
Initial grease fill	467		
Relubrication	468		
Oil lubrication	468		

Designations

Designation system for SDAF housings and standard SDAF extended range housings

SDAF_22634 TA

Housing series

S	Standard pillow block
D	Heavy-duty series
A	Inch dimensions
F	Labyrinth seal

Material

-	Cast iron (standard)
D	Ductile iron (spheroidal graphite cast iron)
S	Cast steel

Size identification

222(00)	Kits with spherical roller bearings with cylindrical bore, diameter series 2
223(00)	Kits with spherical roller bearings with cylindrical bore, diameter series 3
225(00)	Kits with spherical roller bearings on an adapter sleeve, diameter series 2
226(00)	Kits with spherical roller bearings on an adapter sleeve, diameter series 3
230(00)	Kits with spherical roller bearings with a cylindrical bore, diameter series 0
230(00) KA	Kits with spherical roller bearings on an adapter sleeve, diameter series 0
231(00)	Kits with spherical roller bearings with cylindrical bore, diameter series 1
231(00) KA	Kits with spherical roller bearings on an adapter sleeve, diameter series 1
232(00)	Kits with spherical roller bearings with cylindrical bore, diameter series 2
232(00) KA	Kits with spherical roller bearings on an adapter sleeve, diameter series 2
..20 to 96	Size code, related to the bearing bore size
../500 to /530	Size code, related to the bearing bore size

Suffix¹⁾

T	Taconite seal with contact seal or bolt-on taconite seals
TV	Taconite seal with V-ring
TA or TVA	Taconite seal with button head grease fitting
TB or TVB	Taconite seal with giant button head grease fitting
Y	One end closed (i.e. supplied with end plugs)
/VZ...	Special feature / modification

¹⁾ When multiple suffixes are used, they are listed in the same order as they appear here.

Standard housing design

All SDAF housings, which include the extended range, are split pillow (plummer) block housings consisting of a cap and base (→ **fig. 1**). Their robust design can accommodate shock loads and heavy loads from any direction. All SDAF housings have four holes in the base for attachment bolts and tapped holes in their caps for eye bolts.

Features and benefits

All SDAF housings share the following features and benefits:

Stiff housing

The caps and bases are reinforced with extra material (→ **fig. 2**). This improves heat flow away from the bearing outer ring and avoids distortion of the housing bore.

Caps and bases individually marked

The housing base and cap of all SDAF housings are matched during manufacture and are not interchangeable with the caps and bases of other housings. To help avoid mismatch, each cap and base are numbered (→ **fig. 3**).

Fig. 1

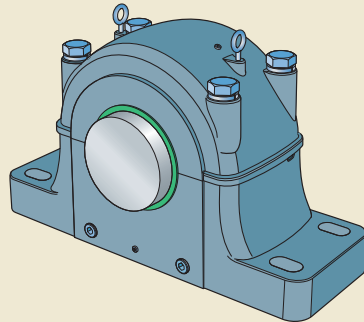

Fig. 2

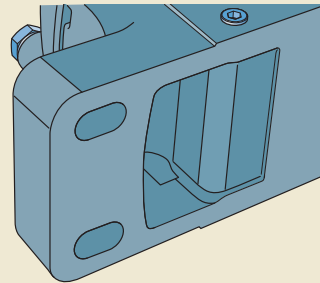
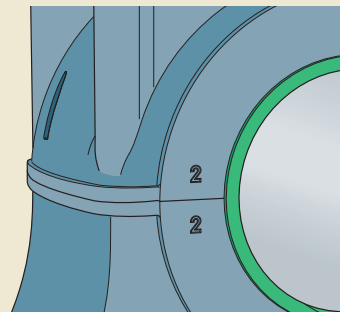

Fig. 3



Housing material

SDAF housings are made standard from ASTM A48 grade 30 grey cast iron, which is equivalent to ISO 185 grade 200. SDAF extended range housings are made standard from ASTM A48 grade 40 grey cast iron, which is equivalent to ISO 185 grade 275.

Paint, corrosion protection

All SDAF housings are painted blue (RAL 5001). The paint protects the housing in accordance with ISO 12944-2, corrosivity category C2 (i.e. exterior atmospheres with low levels of pollution, interior atmospheres where condensation may occur). The paint is not affected by most lubricating or engine oils, cutting fluids or alkalescent washing chemicals. Housings can be repainted with most water solvent based 1- or 2-component paints.

Unpainted surfaces are protected with a rust inhibitor. Special paints or preservatives can be supplied on request.

Housing variants and customization

SDAF and SDAF extended range housings are available with design variants. All variants are individually engineered to meet the requirements of the specific application. Customized variants can include:

- drilled bolt holes in the base
- solid base
- special machining for lubrication
- special housing bore tolerances
- special seals
- milled base ends
- special machining for condition monitoring systems

Because of the highly customized nature of the SDAF extended range housings, the SKF application engineering service and the customer work together to specify and design each housing. This flexible approach provides a host of options tailored to the application, to provide a safe, reliable and cost-effective solution. For additional information contact the SKF application engineering service.

SDAF extended range housings are made-to-order to accommodate any special features that may be required.

Housing material

For applications where extra strength is needed, all SDAF housings are also available in the following materials:

- ductile iron, ASTM A339 grade 60-45-10
- ductile iron, ASTM A339 grade 80-60-03
- cast steel, ASTM A27 grade U-60-30

Sealing solutions

SDAF housings are available with the following sealing solutions (→ fig. 4):

- labyrinth seals (standard)
- labyrinth seals with an internal contact element (PosiTrac Plus)
- taconite heavy-duty seals
- contact seals
- end plugs (end covers)

PosiTrac, PosiTrac Plus and contact seals are not available for SDAF extended range housings.

Table 1, page 456, provides an overview of the characteristics and suitability of each sealing solution. Details are provided in the following text. This information should be used as a guideline, and does not substitute for testing a seal in its application. **Tables 2 and 3 on page 458 and 460** provide an overview about which seals fit what housing.

Labyrinth seals

Labyrinth seals are the standard sealing solution for all SDAF housings. They form a multi-stage labyrinth seal with the seal grooves in the housing. If operating conditions require it, the sealing effect can be enhanced by filling the cavity between the housing and labyrinth ring with grease.

Labyrinth seals for SDAF housings

SDAF housings are supplied with either standard labyrinth seals (designation LER) or PosiTrac labyrinth seals (designation LOR). Both are made of aluminium (→ fig. 4). The PosiTrac labyrinth seals have an additional O-ring made of acrylonitrile-butadiene rubber (NBR) to make the labyrinth ring rotate with the shaft. Whether the standard labyrinth seal or the PosiTrac seal are supplied depends on housing size.

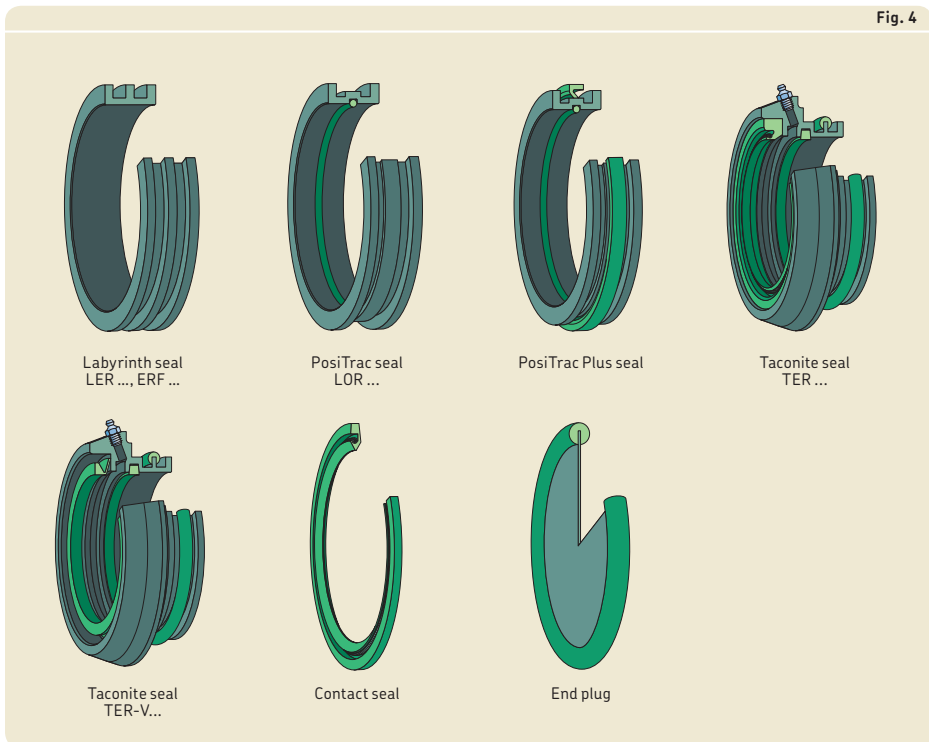



Labyrinth seals for SDAF extended range housings

SDAF extended range housings are supplied as standard with labyrinth rings made of steel, designation ERF (→ **fig. 4**). Special labyrinth rings with O-ring bore inserts are available on request.

Split pillow blocks SDAF series including the extended range (inch dimensions)

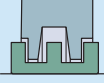
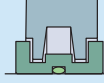
Standard seals for SDAF and SDAF extended range plummer block housings

Seal			
Type	Labyrinth	PosiTrac	PosiTrac Plus
Designation	LER, ERF	LOR	LOR with B-10724
Material	aluminum or steel	aluminum, nitrile rubber	aluminum, nitrile rubber
Application conditions and requirements			
Temperature [°F]	-30 to 300	-30 to 220	-30 to 220
Max. circumferential speed	same as bearing	same as bearing	limited ¹⁾
Misalignment [°]	0,3	0,3	0,3
Low friction	++	++	+
Axial shaft displacement	++	+	-
Vertical shaft arrangement	-	-	++
Grease relubrication	+	+	+
Oil lubrication	-	-	++
Replacement	+	+	+
Sealing suitability			
Dust	-	-	+
Fine particles	-	-	+
Coarse particles	+	+	+
Chips	+	+	-
Liquids when sprayed	--	--	-
Direct sunlight	+	+	+
Symbol:	n/a not applicable ++ very suitable + suitable - limited suitability -- unsuitable		

¹⁾ For speed limits → tables 2 and 3.

²⁾ For more information, contact the SKF application engineering service.

Table 1

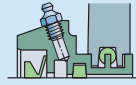

Contact
B-9784

Taconite
TER

Taconite (V-ring seal)
TER V

Bolt-on taconite
split
_2)

End plug
EPR, X 5217

nitrile rubber

steel, felt,
nitrile rubber

steel, felt,
nitrile rubber

cast iron, steel,
nitrile rubber

steel,
nitrile rubber

-30 to 220

-30 to 220

-30 to 220

-30 to 220

-30 to 220

limited¹⁾

limited¹⁾

limited¹⁾

limited

n/a

0,1

0,1

0,5

0,5

n/a

-

--

--

--

n/a

+

+

-

-

n/a

++

++

++

++

++

+

++

++

++

n/a

++

+

+

+

++

+

+

+

+

+

+

++

++

++

+

+

++

++

++

+

+

++

++

++

+

-

++

++

++

-

-

+

+

+

+

+

+

+

+

+

Split pillow blocks SDAF series including the extended range (inch dimensions)

Seal chart for SDAF and SDAFS split pillow block housings

Shaft diameter	d _a 5(00) Series	d _a 6(00) Series	d _b 2(00) Series	d _c 2(00) Series	d _b 3(00) Series	d _c 3(00) Series	Labyrinth seal ¹⁾ Ring seal	O-Ring for LOR ²⁾
in.	in.							
2 ¹³ / ₁₆		617					LOR-57	AS-568-150
2 ⁷ / ₈		617					LOR-58	AS-568-150
2 ¹⁵ / ₁₆		617*					LOR-59	AS-568-151
3		617					LOR-60	AS-568-151
3 ¹ / ₁₆		618					LER-67	–
4 ⁹ / ₁₆	526	626					LOR-119	38309-119
4 ¹ / ₂			220*		320*		LER-205	–
4 ⁹ / ₁₆	528			224*		324*	LOR-119	38309-119
4 ⁷ / ₈	528		222*		322*		LOR-121	AS-568-159
4 ¹⁵ / ₁₆	528*			226*		326*	LOR-122	AS-568-159
5 ¹ / ₈	530	630					LOR-124	AS-568-160
5 ³ / ₁₆	530*	630*					LOR-125	AS-568-160
5 ¹ / ₄	530	630					LOR-126	AS-568-160
5 ⁵ / ₁₆	530	630	224*	228*	324*		LOR-127	38309-127
5 ³ / ₈	530	630					LOR-128	AS-568-161
5 ³ / ₈	532						LOR-129	AS-568-253
5 ⁷ / ₁₆	532*						LOR-130	AS-568-254
5 ¹ / ₂	532						LOR-131	AS-568-254
5 ⁷ / ₁₆		632*					LER-211	–
5 ³ / ₄				230*		330*	LOR-134	AS-568-162
5 ⁷ / ₈			226*		326*		LOR-136	AS-568-163
5 ¹⁵ / ₁₆		634*					LER-215	–
6 ¹ / ₁₆					232*		LOR-142	38309-142
6 ¹ / ₁₆						332*	LER-217	–
6 ¹ / ₄					228*		LOR-144	AS-568-164
6 ⁵ / ₁₆	536						LOR-146	38309-146
6 ³ / ₈	536						LOR-147	AS-568-260
6 ⁷ / ₁₆	536*						LOR-148	AS-568-260
6 ¹ / ₂	536						LOR-149	AS-568-260
6 ⁷ / ₁₆		636*				334*	LER-220	–
6 ⁵ / ₈			230*		330*		LOR-151	AS-568-166
6 ⁷ / ₈				236*			LOR-154	AS-568-262
6 ⁷ / ₈						336*	LER-223	–
6 ¹⁵ / ₁₆	538*	638*					LER-224	–
7			232*				LOR-156	AS-568-262
7					332*		LER-225	–
7 ³ / ₁₆	540*	640*					LER-228	–
7 ¹ / ₄				238*		338*	LER-229	–
7 ⁷ / ₁₆					334*		LER-230	–
7 ⁵ / ₈				240*			LER-233	–
7 ¹³ / ₁₆			236*				LOR-165	AS-568-266
7 ¹³ / ₁₆					336*		LER-234	–
7 ¹⁵ / ₁₆	544*						LER-236	–
8 ⁵ / ₁₆				244*			LER-239	–
8 ³ / ₈			238*		338*		LER-240	–
8 ³ / ₄			240*				LER-244	–
9 ⁹ / ₁₆			244*				LER-248	–

* = Standard shaft diameter, all others are optional shaft diameters

1) Speed rating is the same as bearing speed rating.

2) O-ring supplied with LOR is for replacement only, AS-568-... are industry standard O-rings available.

3) B-10724-... contact seals together with LOR labyrinth seals form PosiTrac Plus seals.

Table 2

Contact seal ³⁾	Speed limit ⁴⁾	Taconite seals with contact seal ⁵⁾	with V-Ring seal	Speed limit ⁴⁾	End plug
–	r/min	–		r/min	–
B-10724-184	1950	TER-57	TER-57 V	1 050	EPR-10
B-10724-184	1950	TER-58	TER-58 V	1 050	EPR-10
B-10724-184	1950	TER-59	TER-59 V	1 050	EPR-10
B-10724-184 – ⁶⁾	1950	TER-60	TER-60 V	1 050	EPR-10
B-10724-117	1300	TER-67	TER-67 V	950	EPR-11
		TER-119	TER-119 V	700	EPR-15
– ⁶⁾	–	TER-205	TER-205 V	675	–
B-10724-117	1300	TER-119	TER-119 V	575	EPR-15
B-10724-122	1150	TER-121	TER-121 V	625	–
B-10724-122	1150	TER-122	TER-122 V	520	EPR-27
B-10724-125	1075	TER-124	TER-124 V	590	EPR-16
B-10724-125	1075	TER-125	TER-125 V	590	EPR-16
B-10724-125	1075	TER-126	TER-126 V	590	EPR-16
B-10724-125	1075	TER-127	TER-127 V	575	–
B-10724-125	1075	TER-128	TER-128 V	575	EPR-16
B-10724-130	1050	TER-129	TER-129 V	575	EPR-16
B-10724-130	1050	TER-130	TER-130 V	560	EPR-16
B-10724-130	1050	TER-131	TER-131 V	560	EPR-16
– ⁶⁾	–	TER-211	TER-211 V	560	EPR-17
B-10724-130	1050	TER-134	TER-134 V	460	EPR-17
B-10724-130	1050	TER-136	TER-136 V	520	–
– ⁶⁾	–	TER-215	TER-215 V	515	EPR-19
B-10724-140	950	TER-142	TER-142 V	435	EPR-18
– ⁶⁾	–	TER-217	TER-217 V	435	EPR-19
B-10724-144	925	TER-144	TER-144 V	–	–
B-10724-148	875	TER-146	TER-146 V	475	EPR-19
B-10724-148	875	TER-147	TER-147 V	475	EPR-19
B-10724-148	875	TER-148	TER-148 V	475	EPR-19
B-10724-148	875	TER-149	TER-149 V	475	EPR-19
– ⁶⁾	–	TER-220	TER-220 V	475	EPR-26
B-10724-151	850	TER-151	TER-151 V	460	–
B-10724-155	825	TER-154	TER-154 V	390	EPR-20
B-9784-130	750	TER-223	TER-223 V	390	EPR-21
– ⁶⁾	–	TER-224	TER-224 V	440	EPR-21
B-10724-155	825	TER-156	TER-156 V	435	–
– ⁶⁾	–	TER-225	TER-225 V	435	–
B-9784-140	800	TER-228	TER-228 V	425	EPR-22
B-9784-141	700	TER-229	TER-229 V	365	EPR-22
– ⁶⁾	–	TER-230	TER-230 V	410	–
B-9784-146	650	TER-233	TER-233 V	350	EPR-23
B-17024-167	725	TER-165	TER-165 V	390	–
B-9784-148	750	TER-234	TER-234 V	390	–
– ⁶⁾	–	TER-236	TER-236 V	385	EPR-24
– ⁶⁾	–	TER-239	TER-239 V	315	EPR-25
– ⁶⁾	–	TER-240	TER-240 V	365	–
B-9784-159	650	TER-244	TER-244 V	350	–
– ⁶⁾	–	TER-248	TER-248 V	315	–

⁴⁾ For stepped shaft housing designs, the largest shaft diameter defines the speed limit.

⁵⁾ Most taconite seals are made to order; contact SKF for availability, all V ring versions are made to order.

⁶⁾ For more information contact the SKF application engineering service.

Split pillow blocks SDAF series including the extended range (inch dimensions)

Table 3

Seal chart for SDAF extended range housings								
Shaft diameter	d _a 230(00) Series	d _a 231(00) Series	d _a 232(00) Series	Labyrinth seal ¹⁾ Ring seal	Taconite seal ²⁾ with contact seal with V-ring seal		Speed limit	End plug
in.	–	–	–	–	–	–	r/min.	–
8 ¹⁵ / ₁₆			3248 KA* ³⁾	ERF-914	TER-914	TER-914 V	280	X-5217-25
9			3248 KA	ERF-828	TER-828	TER-828 V	280	X-5217-25
9 ⁷ / ₁₆		3152 KA* ³⁾	3252 KA* ³⁾	ERF-891	TER-891	TER-891 V	275	X-5217-53
9 ¹ / ₂		3152 KA	3252 KA	ERF-842	TER-842	TER-842 V	275	X-5217-53
9 ¹⁵ / ₁₆		3156 KA		ERF-845	TER-845	TER-845 V	270	X-5217-35
14	3076 KA	3176 KA		ERF-876	TER-876	TER-876 V	215	X-5217-12
14 ¹⁵ / ₁₆	3080 KA* ³⁾			ERF-882	TER-882	TER-882 V	200	–
14 ¹⁵ / ₁₆		3180 KA* ³⁾	3280 KA* ³⁾	ERF-976	TER-976	TER-976 V	200	–
15	3080 KA* ³⁾			ERF-847	TER-847	TER-847 V	200	X-5217-21
15 ³ / ₄	3084 KA* ³⁾			ERF-969	TER-969	TER-969 V	185	X-5217-23
15 ³ / ₄		3184 KA* ³⁾	3284 KA* ³⁾	ERF-907	TER-907	TER-907 V	185	X-5217-5
16 ¹ / ₂	3088 KA* ³⁾	3188 KA* ³⁾	3288 KA* ³⁾	ERF-958	TER-958	TER-958 V	180	–
17	3092 KA* ³⁾	3192 KA* ³⁾		ERF-838	TER-838	TER-838 V	175	X-5217-48
18	3096 KA* ³⁾	3196 KA* ³⁾		ERF-888	TER-888	TER-888 V	170	–
18 ¹ / ₂	230/500 KA* ³⁾			ERF-978	TER-978	TER-978 V	170	–
19 ¹ / ₂	230/500 KA* ³⁾			ERF-926	TER-926	TER-926 V	165	–

* = Standard shaft diameter, all others are optional shaft diameters

¹⁾ Speed rating same as bearing speed rating

²⁾ Bolt-on taconite seals should be used when taconite seals in the TER series are not available.

³⁾ Contact the SKF application engineering service to review alternative optional shaft diameters as special machining of housing labyrinth grooves may be required.

Labyrinth rings with an internal contact element

PosiTrac Plus seals consist of a PosiTrac labyrinth ring (designation LOR) and a contact element made of acrylonitrile-butadiene rubber (NBR). The labyrinth ring is located on the shaft and held in place by an O-ring. The contact element is located in the seal groove in the housing. It can be mounted either for best contaminant exclusion or for best lubricant retention (→ fig. 5). When the contact element is mounted for best contaminant exclusion, the sealing effect can be enhanced by filling the seal cavity with grease. The designation for the contact element is B 10724 followed by a size code, for example B 10724-122.

Taconite heavy-duty seals

Taconite seals consist of an inboard felt seal, a grease cavity and an outboard seal that is available in two designs (→ fig. 4, page 454):

- Seals in the TER series include a split radial shaft seal made of NBR.
- Seals in the TER-V series include a V-ring seal.

To further protect against the ingress of contaminants, SKF taconite seals have a grease fitting to purge old grease and any trapped contaminants from the seal cavity, through the outboard seal.

Taconite heavy-duty seals are available for all smaller SDAF housings, but not all housings in the extended range.

Bolt-on taconite seals

Bolt-on taconite seals consist of a split cast iron auxiliary cover, a split radial shaft seal, a grease fitting and all mounting hardware. Bolt-on taconite seals were developed to accommodate the SDAF extended range housing and provide the equivalent sealing protection as the other taconite heavy-duty seals. All bolt-on taconite seals are custom manu-

factured during the production of the housing and should be ordered together with the housing.

Bolt-on taconite seals are available for all SDAF extended range housings. For SDAF extended range housings, the designation suffix T indicates bolt-on taconite seals, e.g. SDAF 23272 KAT x 13 ⁷/₁₆.

Contact seals

Contact seals are spring-loaded radial shaft seals made of NBR and fit into the seal groove in the housing (→ **fig. 4, page 454**). Contact seals are available for shaft diameters 6 ⁷/₈ and larger, where PosiTrac seals are not available. The designation for contact seals is B 9784 followed by a size code, e.g. B 9784-130.

End plugs

Housings at the end of a shaft should have an end plug (end cover) that fits into the seal groove in the housing (→ **fig. 4, page 454**). The plug consists of a metal plate with a strip made of acrylonitrile-butadiene rubber (NBR). Details of the permissible length of the shaft end are listed in the product tables. End plugs for SDAF and SDAF extended range housings are identified by the series designation EPR or X 5217, followed by the size identification.

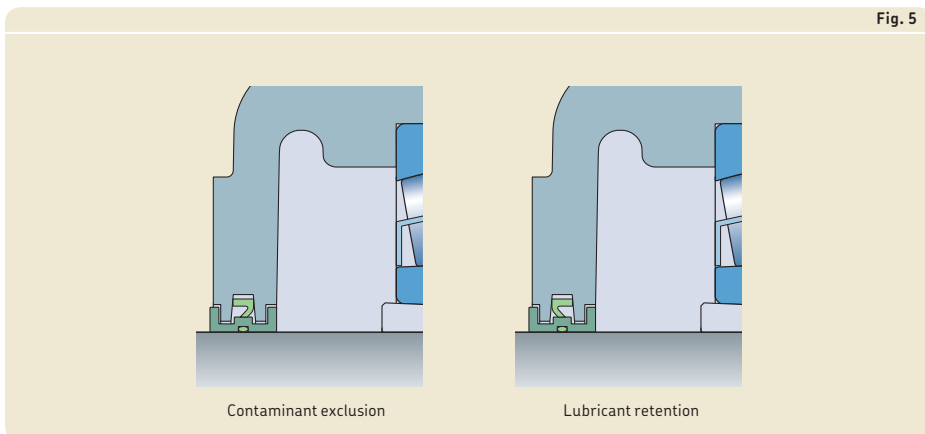

Special seals

In addition to the standard seal assortment, high-temperature contact seals and high-speed seals are available on request, for SDAF housings.

High-temperature seals

High-temperature contact seals (designation LORP) consist of a PTFE labyrinth ring with an FKM (fluoro rubber) O-ring and a PTFE contact element. The PTFE contact element is available separately (designation B-10785).

High-temperature seals can accommodate operating temperatures up to 400 °F. The limiting speed for the bearing can be attained.

High-speed seals

High-speed contact seals consist of an aluminium labyrinth ring with an NBR O-ring (designation LOR) and a PTFE contact element (designation B-10785). With PTFE contact elements, the limiting speed for the bearing can be attained.

WARNING!

Seals made of FKM (fluoro rubber) or PTFE exposed to an open flame or temperatures above 570 °F are a health and environmental hazard! Contact SKF for detailed safety instructions.

Design considerations

For general information about system design, refer to the following sections:

- *Typical shaft-bearing combinations* (→ page 41)
- *Locating/non-locating bearing systems* (→ page 40)
- *Load carrying ability* (→ page 44)
- *Axial load carrying ability for bearings on sleeves* (→ page 44)
- *Specifications for shafts and housing support surfaces* (→ page 45)

For additional information about rolling bearings and adapter sleeves, refer to the product information available online at skf.com/bearings.

Typical shaft-bearing combinations

All SDAF housings can accommodate different shaft-bearing combinations (→ fig. 6):

- Plain shaft with bearing on an adapter sleeve
- Stepped shaft with bearing on a cylindrical seat

Plain shaft with bearing on an adapter sleeve

This arrangement is standard for SDAF pillow blocks in the 225 and 226 series and for SDAF extended range housings in the 230..KA, 231..KA and 232..KA series. Housings, appropriate parts and dimensions are listed in product **tables 9.1** (→ page 472) and **9.3** (→ page 476).

Stepped shaft with bearing on a cylindrical seat

This arrangement is standard for SDAF housings in the 222 and 223 series and for SDAF extended range housings in the 230, 231 and 232 series. Housings, appropriate parts and dimensions are listed in product **tables 9.2** (→ page 474) and **9.4** (→ page 480).

Locating and non-locating bearing positions

All SDAF housings can be used for both the locating and non-locating bearing positions.

The housings are machined standard for bearings in the non-locating position. Bearings in the locating position as well as CARB toroidal roller bearings must be secured in the housing with stabilizing (locating) rings. Appropriate stabilizing rings are supplied with smaller SDAF housings. For SDAF extended range housings, the stabilizing rings must be ordered separately.

Load carrying ability

All SDAF housings are intended for loads acting perpendicularly toward the support surface. If the housing is supported over its entire base and the loads are purely perpendicular, loads are limited only by the bearing.

If loads acting in other directions occur, or if the housing is not supported over its entire base, be sure that the magnitude of the load is permissible for the housing and the attachment bolts.

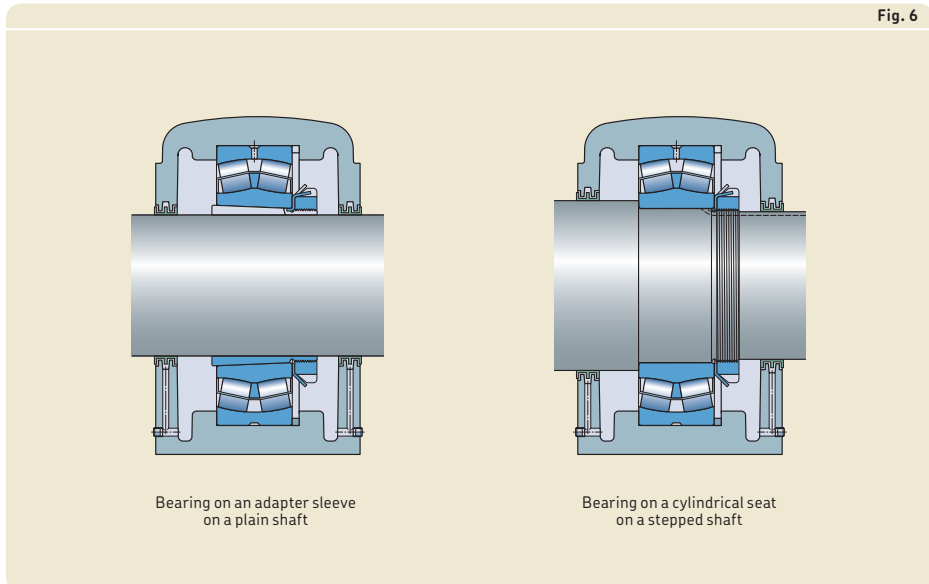

Split pillow blocks SDAF series including the extended range (inch dimensions)

Load carrying ability of the housing

Guideline values for the safe loads of housings made of grey cast iron are listed in **tables 4** and **5**. The safe loads have been calculated using a safety factor of 5 against base fracture and a factor of 2 against cap bolt yield.

For housings made of ductile iron, the values obtained from **tables 4** and **5** should be multiplied by a factor of 1,5 for ASTM A339 grade 60-45-10. For information about ASTM A339 grade 80-60-03, contact the SKF

application engineering service. For purely axial loads, static or dynamic, the loads on the housing should not exceed 65% of P_{180° . For bearings mounted on adapter sleeves, the permissible axial load is dependent on the adapter sleeve.

Table 4

Safe loads and cap bolt information for SDAF cast iron housings

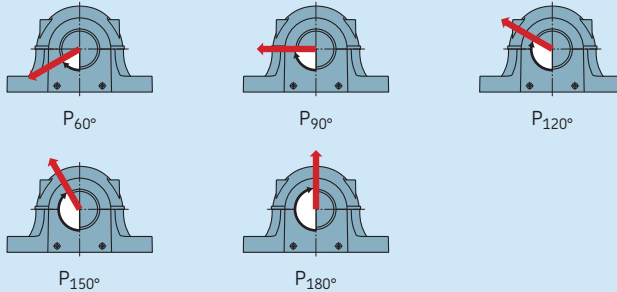

Housing Size				Recommended safe loads					Cap bolt information		
				P _{60°}	P _{90°}	P _{120°}	P _{150°}	P _{180°}	Cap bolt size	Torque	SAE grade
–				lbf.					in.	ft.-lbs.	
220	317	520	617	40 080	24 000	15 000	13 700	16 600	3/4-10	175	2
	318		618	45 900	27 500	17 300	16 000	19 300	3/4-10	175	2
222		522		51 700	31 000	19 600	17 600	21 200	7/8-9	165	2
224	320	524	620	54 000	36 500	23 600	21 600	26 500	7/8-9	165	2
226	322	526	622	60 100	36 000	23 600	21 600	27 000	7/8-9	165	2
230	324	530	624	85 100	51 000	32 000	29 000	35 500	1.1/8-7	350	2
232	326	532	626	83 500	50 000	31 500	28 500	34 500	1.1/8-7	350	2
238	332	538	632	127 000	76 500	47 500	43 000	52 000	1.1/4-7	350	2
240	334	540	634	150 000	90 000	56 000	50 000	60 000	1.1/4-7	350	2
244	336	544	636	141 000	85 000	53 000	48 000	57 000	1.3/8-6	350	2
	338		638	152 000	91 500	57 000	52 000	63 000	1.3/8-6	660	2
	340		640	144 000	86 500	54 000	49 000	58 500	1.3/8-6	660	2

Additional housing support

When the housing is subjected to loads acting parallel to the support surface, it may be necessary to pin the housing to the support surface or to provide a stop to counter the load. When loads act at angles between 60° and 120°, or when the axial loads are greater than 5% of P_{180°}, the housing should be pinned to the support surface or a stop should be provided to counter the load. The dowel pins or stop should be sufficiently strong to accom-

modate the loads acting parallel to the support surface.

Table 5

Safe loads and cap bolt information for SDAF extended range cast iron housings

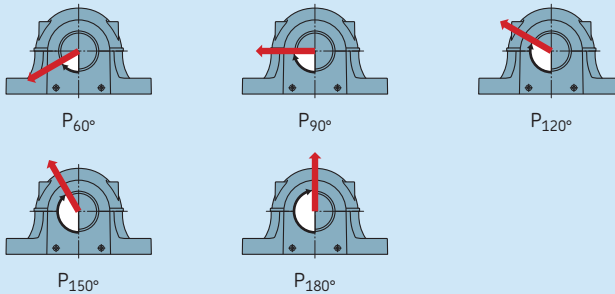

Housing Size	Recommended safe loads					Cap bolt information				
	P _{60°}	P _{90°}	P _{120°}	P _{150°}	P _{180°}	Cap bolt size	Torque	SAE grade		
	lbf.						ft.-lbs.			
3060	3152	3252	294 000	17 600	110 000	98 000	118 000	1.1/2-6	1950	5
3064	3160	3256	408 000	245 000	156 000	143 000	176 000	1.1/2-6	1950	5
3068	3160	3256	408 000	245 000	156 000	143 000	176 000	1.1/2-6	1950	5
3072	3164	3260	442 000	265 000	170 000	153 000	186 000	1.3/4-5	2280	5
3076			442 000	265 000	170 000	153 000	186 000	1.3/4-5	2280	5
3080	3168	3264	517 000	310 000	200 000	186 000	228 000	1.7/8-5	2860	5
3084	3172	3268	650 000	390 000	245 000	224 000	275 000	1.3/4-5	2280	5
	3176		650 000	390 000	245 000	224 000	275 000	1.3/4-5	2280	5
3088	3180	3272	717 000	430 000	275 000	250 000	305 000	1.7/8-5	2860	5
3092	3176	3268	717 000	430 000	275 000	250 000	305 000	1.7/8-5	2860	5
3096	3184	3280	1 050 000	630 000	405 000	375 000	465 000	2-4.1/4	3440	5
30/500	3188		1 050 000	630 000	405 000	375 000	465 000	2-4.1/4	3440	5
30/530	3192	3284	900 000	540 000	345 000	320 000	400 000	2.1/4-4.1/2	5030	5
	3196	3288	900 000	540 000	345 000	320 000	400 000	2.1/4-4.1/2	5030	5

Operating temperature

The permissible operating temperature is mainly limited by the seals (→ **table 1** on **page 456**) and the lubricant in the bearing. For temperature limits of SKF bearings and lubricants, refer to the product information available online at skf.com/bearings.

The housing material does not have any additional temperature limits, except for very low temperature applications where impact strength could be a factor. For additional information, contact the SKF application engineering service.

The housing paint is heat resistant up to 175 °F material temperature or 210 °F ambient temperature. When temperatures outside the permissible range are expected, contact the SKF application engineering service.

Attachment bolt recommendations

In typical applications, 8.8 class (SAE J429, Grade 5) hexagon head bolts can be used together with washers. If the load does not act perpendicularly toward the base, it may be necessary to use stronger, 10.9 class (SAE J429, Grade 8) bolts.

SKF housings can withstand loads resulting from tightening the attachment bolts to the torque values recommended by bolt manufacturers. They are valid for oiled, but otherwise untreated, thread surfaces. SKF cannot guarantee that tightening to the recommended value will provide sufficient anchoring. Make sure that attachment bolts, dowels or stops, and a sufficiently strong support can accommodate all occurring loads.

Operating speed

All seals, except non-contact labyrinth seals, limit the permissible operating speed. Speed limits for seals are provided in **table 1** on **page 456**. For speed limits of the bearing, refer to the product information available online at skf.com/bearings.

Shaft specifications

Table 6 lists the recommended shaft diameter tolerances. The values d_a , d_b and d_c are listed in the product tables starting on **page 472**. The tolerance class for the bearing shaft seat should be selected from the SKF rolling bearings catalogue.

Table 6

Shaft tolerances					
Nominal diameter over	incl.	Diameter tolerance limits			
		Adapter mounting d_a		Cylindrical mounting d_b, d_c	
		high	low	high	low
in.		in.			
1/2	1	0	-0.002	-	-
1	2	0	-0.003	0	-0.003
2	4	0	-0.004	0	-0.003
4	6	0	-0.005	0	-0.003
6	10	0	-0.006	0	-0.004
10	15	0	-0.006	0	-0.005
15		0	-0.006	0	-0.006

Lubrication

All SDAF pillow blocks can accommodate grease, oil bath or circulating oil lubrication systems. Any sealing solution can be used with grease lubrication, while for oil lubrication SKF does not recommend using labyrinth rings in the LER series.

The lubricant should be selected based on the operating conditions of the bearing. For additional information about lubricant selection, refer to the information available online at skf.com/bearings.

Initial grease fill

If no other requirements exist, the free space in the bearing should be completely filled with grease and the free space in the housing should be filled 20 to 40% of its volume. A 40% grease fill is required when bearings have to be relubricated from the side, while a 20% grease fill

is used when bearings are relubricated via the outer ring.

For highly contaminated environments and slow speeds, fill the housing to 70 to 80%. For additional information, contact the SKF application engineering service.

Quantities for 20 and 40% fills are listed in **tables 7** and **8**. The values are valid for a typical lithium grease (about 0,57 oz/in³). The grease to fill labyrinth seals or taconite heavy-duty seals is not included.

In most applications, the initial grease fill will adequately lubricate the bearing until the grease is exchanged during the next planned inspection.

Table 7

Initial grease fill for SDAF pillow block housings

Housing Size	Initial fill	
	20%	40%
–	oz.	
220	316	616
	317	617
	318	618
222	522	622
	524	620
	526	622
224	320	620
	322	622
	526	622
226	322	622
	526	622
	622	622
228	528	628
	530	624
	532	626
230	324	624
	326	626
	532	626
232	326	626
	532	626
	626	626
234	328	628
	330	630
	332	632
236	330	630
	332	632
	538	632
238	332	632
	538	632
	632	632
240	334	634
	336	636
	340	640
244	338	638
	340	640
	544	640

Table 8

Initial grease fill for SDAF extended range pillow block housings

Housing Size	Initial fill	
	20%	40%
–	lb.	
3060	3152	3248
	3156	3252
	3160	3256
3072	3164	3260
	3168	3264
	3264	3264
3080	3172	3268
	3176	3272
	3180	3276
3088	3180	3280
	3268	3284
	3276	3288
3092	3184	3288
	3188	3292
	3276	3296
3096	3184	3288
	3188	3292
	3276	3296
30/500	3188	3288
	3192	3292
	3284	3296
30/530	3192	3288
	3196	3292
	3284	3296

Split pillow blocks SDAF series including the extended range (inch dimensions)

Relubrication

All SDAF housings have one drilled and tapped lubrication hole in the centre of the cap (\rightarrow **fig. 7**). The hole is plugged on delivery.

All housing bases are equipped with a drain plug on each side to purge or drain old lubricant or to serve as an outlet for circulating oil (\rightarrow **fig. 8**). The sump in the housing base is large enough to accommodate a sufficient quantity of lubricant to provide reliable long-term operation.

Relubrication via the outer ring

The hole in the centre of the cap should be used to relubricate spherical roller bearings with a relubrication feature (a lubrication groove and holes in the outer ring) (\rightarrow **fig. 9**). When applying grease via the relubrication feature, the shaft should be rotating.

Oil lubrication

Oil bath lubrication

The level of oil should be at about the centre of the lowermost rolling element when the bearing is stationary. For more information about oil levels, contact the SKF application engineering service. For higher speeds, the level should be slightly lower to reduce the effects of lubricant churning – about $\frac{1}{8}$ inch above the corner of the outer ring raceway of the bearing.

An oil sight glass should be used to monitor the oil level during operation. It can be mounted into one of the drain holes in the housing base. The static oil level should be marked on the sight glass prior to operation and a running level should be marked after start up. Depending on the type of bearing and the speed and direction of rotation, the running level will either rise or fall from the static level.

Fig. 7

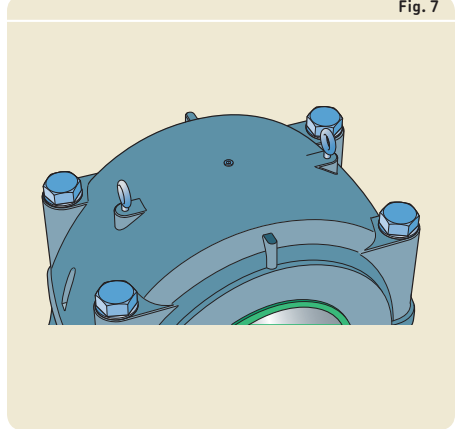

Fig. 8

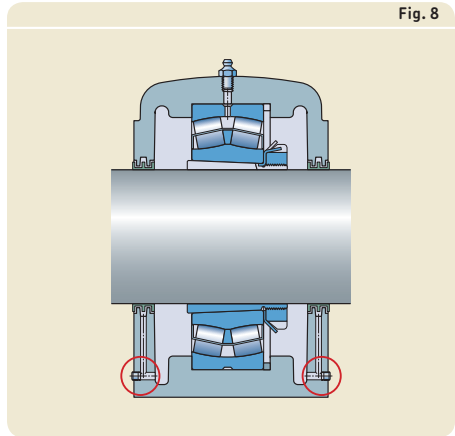
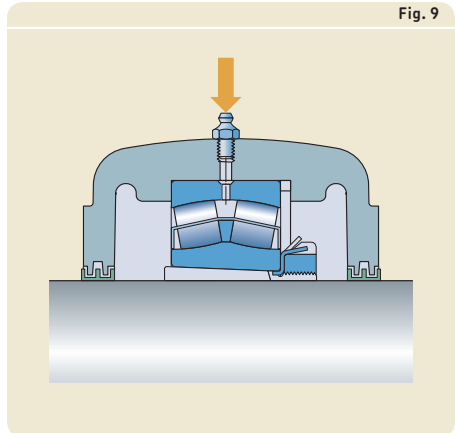

Fig. 9



Circulating oil lubrication system

When using a circulating oil lubrication system with any SDAF housing, oil is introduced through the inlet holes in the housing cap and drained from one or both sides of the base.

Drains should lead downward immediately outside of the housing to prevent oil from accumulating in the housing. Too high an oil level can result in higher operating temperatures due to churning of the lubricant. The drain pipes must be adequately sized and arranged to allow oil to drain from the housing. Additional considerations may be necessary when using a circulating oil system. These can include special housing seals, cross drilling the housing sump, wet sump requirements, flow rates, and drain hole dimensions. For more information, contact the SKF application engineering service.

Mounting

All SDAF housings must be mounted properly using the appropriate tools and state of the art mechanical mounting methods. All the associated components must also meet certain basic requirements (→ *Specifications for shafts and housing support surfaces* on **page 45**). Mounting instructions are provided with the housing. For information about mounting rolling bearings, refer to skf.com/mount.

Cap bolt torque specifications

Cap bolts should be tightened to the torque values listed in **tables 4 and 5** on **page 464** and **465**.

Pinning or supporting the housing

Some load conditions may require the housing to be pinned to its support surface or a stop to accommodate loads acting parallel to the housing support surface (→ *Additional housing support*, **page 465**).

Condition monitoring

All SDAF pillow block housings support condition monitoring during operation. They offer space to attach sensors on the cap, side and front faces of the housing for different condition monitoring equipment.

For additional information about condition monitoring and the measurement tools and systems available from SKF, contact the SKF application engineering service.

Ordering information

SDAF pillow blocks are available as complete kits including housing, seals, bearing (and adapter sleeve), locking device and a standard locating ring. A complete pillow block is specified by a designation provided in the product tables for the different series. Optional features can be specified with prefix and suffixes. If several suffixes are required, put them in alphabetical order.

SDAF extended range pillow blocks are typically sold as housing only including labyrinth seals. Complete kits are available that include housing, seals, bearing, adapter assembly or locking device and locating ring.

All pillow block parts can also be supplied as individual components. Order designations for the different parts are listed in the product tables for the different series.

Order example

A shaft with 4 ³/₁₆ inch diameter has to be supported by two SDAF pillow (plummer) blocks with 22224 EK spherical roller bearings on adapter sleeves, one at the shaft end for a non-locating bearing position and one for a through shaft at the locating bearing position. The housings should be sealed with PosiTrac Plus seals.

Order:

- 1 pillow block SDAF 22524 TLCY
- 1 pillow block SDAF 22524 TLC

The delivery will contain:

- 2 housings SDAF 524
- 2 spherical roller bearings 22224 EK
- 2 adapter sleeves with lock nuts SNW 24x4.3/16
- 2 locating rings SR 24-20
- 3 labyrinth rings with O-rings LOR 113
- 3 contact elements B-10724-113
- 1 end plug EPR 14

9.1 SDAF pillow blocks with spherical roller bearings on an adapter sleeve Series SDAF 225(00), 226(00)

d_a 2 ¹⁵/₁₆ – 7 ¹⁵/₁₆ in.

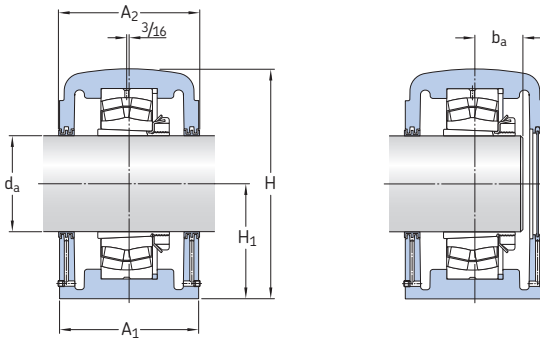

Units of measurement
In this chapter only imperial units are used. To convert imperial units to metric units, refer to the conversion table on page 10.

Shaft diameter		Complete pillow block	Components Pillow block housing	Bearing ²⁾	Adapter assembly	Stabilizing ring ³⁾ (1 incl.)	Labyrinth ring (2 incl.)	Mass
Standard	Optional ¹⁾							
d_a								
in.		–	–					lb.
2 ¹⁵ / ₁₆	2 ¹³ / ₁₆ , 2 ⁷ / ₈ , 3	SDAF 22617	SDAF 617	22317 EK	SNW 117	SR 20-17	LER 59	84
3 ⁷ / ₁₆	3 ⁵ / ₁₆ , 3 ³ / ₈ , 3 ¹ / ₂	SDAF 22520 SDAF 22620	SDAF 520 SDAF 620	22220 EK 22320 EK	SNW 20 SNW 120	SR 20-17 SR 24-20	LER 75 LER 75	96 164
3 ¹⁵ / ₁₆	3 ¹³ / ₁₆ , 3 ⁷ / ₈ , 4	SDAFS 22522⁴⁾ SDAF 22622	SDAFS 522 SDAF 622	22222 EK 22322 EK	SNW 22 SNW 122	SR 22-19 SR 0-22	LER 93 LER 93	105 178
4 ³ / ₁₆	4 ¹ / ₁₆ , 4 ¹ / ₈ , 4 ¹ / ₄	SDAF 22524 SDAF 22624	SDAF 524 SDAF 624	22224 EK 22324 CCK/W33	SNW 24 SNW 124	SR 24-20 SR 0-24	LOR 113 LOR 113	125 272
4 ⁷ / ₁₆	4 ⁵ / ₁₆ , 4 ³ / ₈ , 4 ¹ / ₂	SDAF 22526 SDAF 22626	SDAF 526 SDAF 626	22226 EK 22326 CCK/W33	SNW 26 SNW 126	SR 26-0 SR 0-26	LOR 117 LOR 117	199 340
4 ¹⁵ / ₁₆	4 ¹³ / ₁₆ , 4 ⁷ / ₈ , 5	SDAFS 22528⁴⁾	SDAFS 528	22228 CCK/W33	SNW 28	SR 28-0	LOR 122	220
5 ³ / ₁₆	5 ¹ / ₈ , 5 ¹ / ₄	SDAF 22530	SDAF 530	22230 CCK/W33	SNW 30	SR 30-0	LOR 125	259
5 ⁷ / ₁₆	5 ³ / ₈ , 5 ¹ / ₂	SDAF 22532 SDAF 22632	SDAF 532 SDAF 632	22232 CCK/W33 22332 CCK/W33	SNW 32 SNW 132	SR 32-0 SR 38-32	LOR 130 LER 211	330 455
5 ¹⁵ / ₁₆	5 ¹³ / ₁₆ , 5 ⁷ / ₈ , 6	SDAF 22634	SDAF 634	22334 CCK/W33	SNW 134	SR 40-34	LER 215	530
6 ⁷ / ₁₆	6 ⁵ / ₁₆ , 6 ³ / ₈ , 6 ¹ / ₂	SDAF 22536	SDAF 536	22236 CCK/W33	SNW 36	SR 36-30	LOR 148	403
6 ⁷ / ₁₆	6 ⁵ / ₁₆ , 6 ³ / ₈ , 6 ¹ / ₂	SDAF 22636	SDAF 636	22336 CCK/W33	SNW 136	SR 0-36	LER 220	630
6 ¹⁵ / ₁₆	6 ¹³ / ₁₆ , 6 ⁷ / ₈ , 7	SDAF 22538 SDAF 22638	SDAF 538 SDAF 638	22238 CCK/W33 22338 CCK/W33	SNW 38 SNW 138	SR 38-32 SR 44-38	LER 224 LER 224	454 792
7 ³ / ₁₆	7 ¹ / ₈ , 7 ¹ / ₄	SDAF 22540	SDAF 540	22240 CCK/W33	SNW 40	SR 40-34	LER 228	544
7 ¹⁵ / ₁₆	7 ¹³ / ₁₆ , 7 ⁷ / ₈ , 8	SDAF 22544	SDAF 544	22244 CCK/W33	SNW 44	SR 44-38	LER 236	795

¹⁾ Optional shaft diameters require different adapter sleeve and seals.

²⁾ Optional internal radial clearance (e.g. C3) available on request.

³⁾ For a free unit, discard the enclosed stabilizing ring.

⁴⁾ Available only in steel.

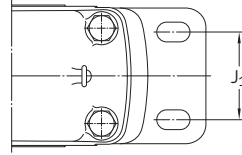
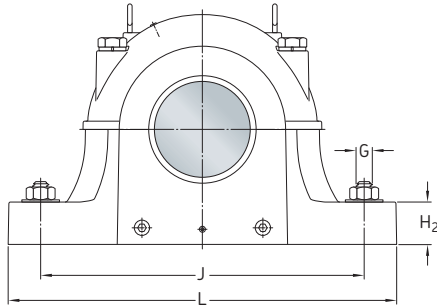

Complete pillow block

Designation Dimensions

	A ₁	A ₂	b _a	H	H ₁	H ₂	J _{min}	J _{max}	J ₁	L	G
–	in.										
SDAF 22617	6	6 3/4	2 1/16	8 15/16	4 1/2	1 7/8	11 5/8	13 1/8	3 3/8	15 1/4	3/4
SDAF 22520	6	6 3/4	1 59/64	8 15/16	4 1/2	1 7/8	11 5/8	13 1/8	3 3/8	15 1/4	3/4
SDAF 22620	6 7/8	7 3/8	2 7/16	10 1/2	5 1/4	2 1/4	13 1/4	14 1/2	4 1/8	16 1/2	7/8
SDAFS 22522	6 3/4	7 1/4	2 1/8	9 7/8	4 15/16	2 1/8	12 5/8	14 1/2	4	16 1/2	7/8
SDAF 22622	7 1/2	8	2 5/8	11 7/8	6	2 3/8	14 5/8	16	4 1/2	18 3/8	1
SDAF 22524	6 7/8	7 3/8	2 9/32	10 1/2	5 1/4	2 1/4	13 1/4	14 1/2	4 1/8	16 1/2	7/8
SDAF 22624	7 7/8	8 3/8	2 13/16	12 9/16	6 5/16	2 1/2	17	18 1/4	4 3/4	21 1/4	1 1/8
SDAF 22526	7 1/2	8	2 15/32	11 7/8	6	2 3/8	14 5/8	16	4 1/2	18 3/8	1
SDAF 22626	8 1/4	8 3/4	3	13 7/16	6 11/16	2 1/2	17 3/8	19 1/4	5	22	1 1/8
SDAFS 22528	7 1/2	7 13/16	–	12 1/16	6	2 3/8	16	17 1/8	4 1/2	20 1/8	1 1/8
SDAF 22530	7 7/8	8 3/8	2 49/64	12 9/16	6 5/16	2 1/2	17	18 1/4	4 3/4	21 1/4	1 1/8
SDAF 22532	8 1/4	8 3/4	2 31/32	13 7/16	6 11/16	2 1/2	17 3/8	19 1/4	5	22	1 1/8
SDAF 22632	10	10 5/8	3 5/8	16	7 7/8	3	21 1/2	23 1/2	6 1/4	27 5/8	1 3/8
SDAF 22634	10 1/2	11 1/8	3 3/4	16 7/8	8 1/4	3 1/4	23	25	6 3/4	28 3/4	1 3/8
SDAF 22536	9 3/8	10	3 9/64	15 3/16	7 1/2	2 3/4	20 7/8	23 5/8	5 7/8	26 3/4	1 1/4
SDAF 22636	10 3/4	11 3/8	3 15/16	17 15/16	8 7/8	3 1/4	24 1/8	26 3/8	6 7/8	30 1/2	1 1/2
SDAF 22538	10	10 5/8	3 19/64	16	7 7/8	3	21 1/2	23 1/2	6 1/4	27 5/8	1 3/8
SDAF 22638	11 1/4	11 7/8	4 1/16	19	9 1/2	3 1/2	25 5/8	27 7/8	7 1/4	32	1 1/2
SDAF 22540	10 1/2	11 1/8	3 1/2	16 7/8	8 1/4	3 1/4	23	25	6 3/4	28 3/4	1 3/8
SDAF 22544	11 1/4	11 7/8	3 5/8	19	9 1/2	3 1/2	25 5/8	27 7/8	7 1/4	32	1 1/2

9.2 SDAF pillow blocks with spherical roller bearings on a cylindrical seat Series SDAF 222(00), 223(00)

d_a 85 – 220 mm

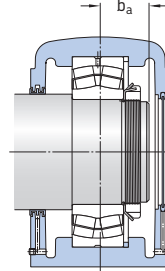
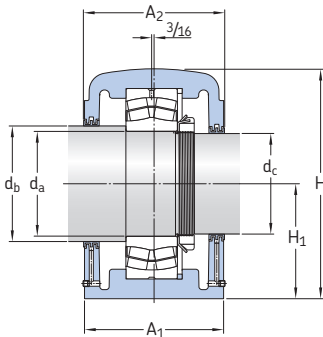

Units of measurement
In this chapter only imperial units are used. To convert imperial units to metric units, refer to the conversion table on page 10.

Shaft diameter			Complete pillow block	Components		Stabilizing ring ²⁾ (1 incl.)	Labyrinth seal Shaft d_b	Labyrinth seal Shaft d_c	Lock nut	Lock washer	Mass
d_a	d_b	d_c		Pillow block housing	Bearing ¹⁾						
mm	in.		-	-							lb.
85	3 15/16	3 3/16	SDAF 22317	SDAF 317	22317 E	SR 20-17	LER 93	LER 69	AN 17	W 17	83
100	4 1/2	3 13/16	SDAF 22220	SDAF 220	22220 E	SR 20-17	LER 205	LER 87	AN 20	W 20	80
			SDAF 22320	SDAF 320	22320 E	SR 24-20	LER 205	LER 87	AN 20	W 20	141
110	4 7/8	4 3/16	SDAFS 22222³⁾	SDAFS 222	22222 E	SR 22-19	LOR 121	LOR 113	AN 22	W 22	102
			SDAF 22322	SDAF 322	22322 E	SR 0-22	LOR 121	LOR 113	AN 22	W 22	172
120	5 5/16	4 9/16	SDAF 22224	SDAF 224	22224 E	SR 24-20	LOR 127	LOR 119	AN 24	W 24	118
			SDAF 22324	SDAF 324	22324 CC/W33	SR 0-24	LOR 127	LOR 119	AN 24	W 24	304
130	5 7/8	4 15/16	SDAF 22226	SDAF 226	22226 E	SR 26-0	LOR 136	LOR 122	AN 26	W 26	169
			SDAF 22326	SDAF 326	22326 CC/W33	SR 0-26	LOR 136	LOR 122	AN 26	W 26	330
140	6 1/4	5 5/16	SDAFS 22228³⁾	SDAFS 228	22228 CC/W33	SR 28-0	LOR 144	LOR 127	AN 28	W 28	175
			SDAF 22328	SDAF 328	22328 CC/W33	SR 0 28	LOR 144	LOR 127	AN 28	W 28	331
150	6 5/8	5 3/4	SDAF 22230	SDAF 230	22230 CC/W33	SR 30-0	LOR 151	LOR 134	AN 30	W 30	200
			SDAF 22330	SDAF 330	22330 CC/W33	SR 36-30	LOR 151	LOR 134	AN 30	W 30	466
160	7	6 1/16	SDAF 22232	SDAF 232	22232 CC/W33	SR 32-0	LOR 156	LOR 142	AN 32	W 32	264
			SDAF 22332	SDAF 332	22332 CC/W33	SR 38-32	LER 225	LER 217	AN 32	W 32	537
170	7 7/16	6 7/16	SDAF 22334	SDAF 334	22334 CC/W33	SR 40-34	LER 230	LER 220	AN 34	W 34	554
180	7 13/16	6 7/8	SDAF 22236	SDAF 236	22236 CC/W33	SR 36-30	LOR 165	LOR 154	AN 36	W 36	436
			SDAF 22336	SDAF 336	22336 CC/W33	SR 0-36	LER 234	LER 223	AN 36	W 36	623
190	8 3/8	7 1/4	SDAF 22238	SDAF 238	22238 CC/W33	SR 38-32	LER 240	LER 229	AN 38	W 38	510
			SDAF 22338	SDAF 338	22338 CC/W33	SR 44-38	LER 240	LER 229	AN 38	W 38	734
200	8 3/4	7 5/8	SDAF 22240	SDAF 240	22240 CC/W33	SR 40-34	LER 244	LER 233	AN 40	W 40	389
220	9 9/16	8 5/16	SDAF 22244	SDAF 244	22244 CC/W33	SR 44-38	LER 248	LER 239	N 44	W 44	787

¹⁾ Optional internal radial clearance (e.g. C3) available on request.

²⁾ For a free unit, discard the enclosed stabilizing ring.

³⁾ Available only in steel.

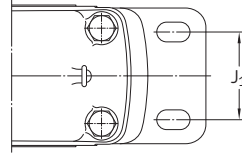
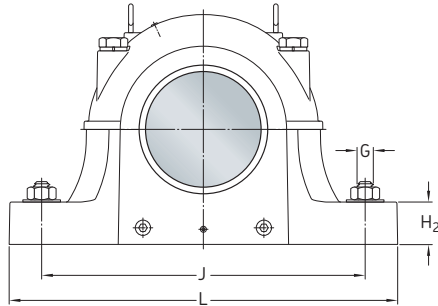

Complete pillow block

Designation Dimensions

	A ₁	A ₂	b _a	H	H ₁	H ₂	J _{min}	J _{max}	J ₁	L	G
–	in.										
SDAF 22317	6	6 ³ / ₄	2 ¹ / ₁₆	8 ¹⁵ / ₁₆	4 ¹ / ₂	1 ⁷ / ₈	11 ⁵ / ₈	13 ¹ / ₈	3 ³ / ₈	15 ¹ / ₄	3 ³ / ₄
SDAF 22220	6	6 ³ / ₄	1 ⁵⁹ / ₆₄	8 ¹⁵ / ₁₆	4 ¹ / ₂	1 ⁷ / ₈	11 ⁵ / ₈	13 ¹ / ₈	3 ³ / ₈	15 ¹ / ₄	3 ³ / ₄
SDAF 22320	6 ⁷ / ₈	7 ³ / ₈	2 ⁷ / ₁₆	10 ¹ / ₂	5 ¹ / ₄	2 ¹ / ₄	13 ¹ / ₄	14 ¹ / ₂	4 ¹ / ₈	16 ¹ / ₂	7 ⁷ / ₈
SDAFS 22222	6 ³ / ₄	7 ¹ / ₄	2 ¹ / ₈	9 ⁷ / ₈	4 ¹⁵ / ₁₆	2 ¹ / ₈	12 ⁵ / ₈	14 ¹ / ₂	4	16 ¹ / ₂	7 ⁷ / ₈
SDAF 22322	7 ¹ / ₂	8	2 ⁵ / ₈	11 ⁷ / ₈	6	2 ³ / ₈	14 ⁵ / ₈	16	4 ¹ / ₂	18 ³ / ₈	1
SDAF 22224	6 ⁷ / ₈	7 ³ / ₈	2 ⁹ / ₃₂	10 ¹ / ₂	5 ¹ / ₄	2 ¹ / ₄	13 ¹ / ₄	14 ¹ / ₂	4 ¹ / ₈	16 ¹ / ₂	7 ⁷ / ₈
SDAF 22324	7 ⁷ / ₈	8 ³ / ₈	2 ¹³ / ₁₆	12 ⁹ / ₁₆	6 ⁵ / ₁₆	2 ¹ / ₂	17	18 ¹ / ₄	4 ³ / ₄	21 ¹ / ₄	1 ¹ / ₈
SDAF 22226	7 ¹ / ₂	8	2 ¹⁵ / ₃₂	11 ⁷ / ₈	6	2 ³ / ₈	14 ⁵ / ₈	16	4 ¹ / ₂	18 ³ / ₈	1
SDAF 22326	8 ¹ / ₄	8 ³ / ₄	3	13 ⁷ / ₁₆	6 ¹¹ / ₁₆	2 ¹ / ₂	17 ³ / ₈	19 ¹ / ₄	5	22	1 ¹ / ₈
SDAFS 22228	7 ¹ / ₂	7 ³ / ₁₆	–	12 ¹ / ₁₆	6	2 ³ / ₈	16	17 ¹ / ₈	4 ¹ / ₂	20 ¹ / ₈	1
SDAF 22328	9	9 ³ / ₈	3 ¹ / ₄	14 ¹ / ₄	7 ¹ / ₁₆	2 ¹ / ₂	19 ³ / ₈	21 ⁵ / ₈	5 ¹ / ₂	24 ³ / ₄	1 ¹ / ₄
SDAF 22230	7 ⁷ / ₈	8 ³ / ₈	2 ⁴⁹ / ₆₄	12 ⁹ / ₁₆	6 ⁵ / ₁₆	2 ¹ / ₂	17	18 ¹ / ₄	4 ³ / ₄	21 ¹ / ₄	1 ¹ / ₈
SDAF 22330	9 ³ / ₈	9 ³ / ₄	3 ⁷ / ₁₆	15 ³ / ₁₆	7 ¹ / ₂	2 ³ / ₄	20 ⁷ / ₈	23 ⁵ / ₈	5 ⁷ / ₈	26 ³ / ₄	1 ¹ / ₄
SDAF 22232	8 ¹ / ₄	8 ³ / ₄	2 ³¹ / ₃₂	13 ⁷ / ₁₆	6 ¹¹ / ₁₆	2 ¹ / ₂	17 ³ / ₈	19 ¹ / ₄	5	22	1 ¹ / ₈
SDAF 22332	10	10 ⁵ / ₈	3 ⁵ / ₈	16	7 ⁷ / ₈	3	21 ¹ / ₂	23 ¹ / ₂	6 ¹ / ₄	27 ⁵ / ₈	1 ³ / ₈
SDAF 22334	10 ¹ / ₂	11 ¹ / ₈	3 ³ / ₄	16 ⁷ / ₈	8 ¹ / ₄	3 ¹ / ₄	23	25	6 ³ / ₄	28 ³ / ₄	1 ³ / ₈
SDAF 22236	9 ³ / ₈	10	3 ⁹ / ₆₄	15 ³ / ₁₆	7 ¹ / ₂	2 ³ / ₄	20 ⁷ / ₈	23 ⁵ / ₈	5 ⁷ / ₈	26 ³ / ₄	1 ¹ / ₄
SDAF 22336	10 ³ / ₄	11 ³ / ₈	3 ⁷ / ₈	17 ¹⁵ / ₁₆	8 ⁷ / ₈	3 ¹ / ₄	24 ¹ / ₈	26 ³ / ₈	6 ⁷ / ₈	30 ¹ / ₂	1 ¹ / ₂
SDAF 22238	10	10 ⁵ / ₈	3 ¹⁹ / ₆₄	16	7 ⁷ / ₈	3	21 ¹ / ₂	23 ¹ / ₂	6 ¹ / ₄	27 ⁵ / ₈	1 ³ / ₈
SDAF 22338	11 ¹ / ₄	11 ⁷ / ₈	4 ¹ / ₁₆	19	9 ¹ / ₂	3 ¹ / ₂	25 ⁵ / ₈	27 ⁷ / ₈	7 ¹ / ₄	32	1 ¹ / ₂
SDAF 22240	10 ¹ / ₂	11 ¹ / ₈	3 ¹ / ₂	16 ⁷ / ₈	8 ¹ / ₄	3 ¹ / ₄	23	25	6 ³ / ₄	28 ³ / ₄	1 ³ / ₈
SDAF 22244	11 ¹ / ₄	11 ⁷ / ₈	3 ⁵ / ₈	19	9 ¹ / ₂	3 ¹ / ₂	25 ⁵ / ₈	27 ⁷ / ₈	7 ¹ / ₄	32	1 ¹ / ₂

9.3 Extended range pillow blocks with spherical roller bearings on an adapter sleeve

Series SDAF 230(00) KA, 231(00) KA, 232(00) KA

d_a 8 ¹⁵/₁₆ – 14 ¹⁵/₁₆ in.

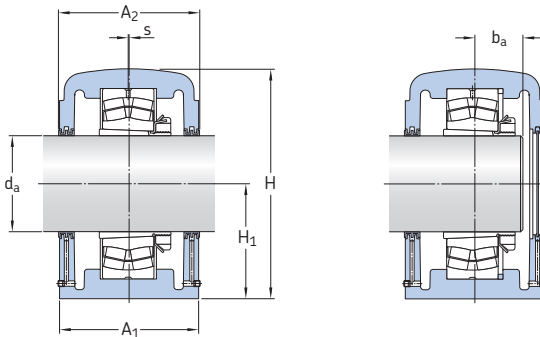

Units of measurement
In this chapter only imperial units are used. To convert imperial units to metric units, refer to the conversion table on page 10.

Shaft diameter Standard d_a	Op- tional ¹⁾	Complete pillow block	Components Pillow block housing	Bearing ²⁾	Adapter assembly	Stabilizing ring ³⁾ (2 req'd)	Laby- rinth ring (2 incl.)
in	-	-	-	-	-	-	-
8 ¹⁵ / ₁₆	9	SDAF 23248 KA x 8 ¹⁵ / ₁₆	SDAF 3248 KA x 8 ¹⁵ / ₁₆	23248 CACK/W33	SNP 148 x 8 ¹⁵ / ₁₆	36053-114	ERF 914
9 ⁷ / ₁₆	9 1/2	SDAF 23152 KA x 9 ⁷ / ₁₆ SDAF 23252 KA x 9 ⁷ / ₁₆	SDAF 3152 KA x 9 ⁷ / ₁₆ SDAF 3252 KA x 9 ⁷ / ₁₆	23152 CACK/W33 23252 CACK/W33	SNP 3152 x 9 ⁷ / ₁₆ SNP 152 x 9 ⁷ / ₁₆	36053-114 A 8968	ERF 891 ERF 891
10 ⁷ / ₁₆	10 1/2	SDAF 23156 KA x 10 ⁷ / ₁₆ SDAF 23256 KA x 10 ⁷ / ₁₆	SDAF 3156 KA x 10 ⁷ / ₁₆ SDAF 3256 KA x 10 ⁷ / ₁₆	23156 CACK/W33 23256 CACK/W33	SNP 3156 x 10 ⁷ / ₁₆ SNP 3256 x 10 ⁷ / ₁₆	A 8967 36053-157	ERF 973 ERF 973
10 ¹⁵ / ₁₆	11	SDAF 23060 KA x 10 ¹⁵ / ₁₆ SDAF 23160 KA x 10 ¹⁵ / ₁₆	SDAF 3060 KA x 10 ¹⁵ / ₁₆ SDAF 3160 KA x 10 ¹⁵ / ₁₆	23060 CACK/W33 23160 CACK/W33	SNP 3060 x 10 ¹⁵ / ₁₆ SNP 3160 x 10 ¹⁵ / ₁₆	A 8967 ⁴⁾ 36053-157	ERF 858 ERF 858
10 ¹⁵ / ₁₆	11	SDAF 23260 KA x 10 ¹⁵ / ₁₆	SDAF 3260 KA x 10 ¹⁵ / ₁₆	23260 CACK/W33	SNP 3260 x 10 ¹⁵ / ₁₆	36053-130	ERF 1002
11 ⁷ / ₁₆	11 1/2	SDAF 23064 KA x 11 ⁷ / ₁₆	SDAF 3064 KA x 11 ⁷ / ₁₆	23064 CCK/W33	SNP 3064 x 11 ⁷ / ₁₆	A 8968 ⁴⁾	ERF 861
11 ¹⁵ / ₁₆	12	SDAF 23064 KA x 11 ¹⁵ / ₁₆ SDAF 23164 KA x 11 ¹⁵ / ₁₆ SDAF 23264 KA x 11 ¹⁵ / ₁₆	SDAF 3064 KA x 11 ¹⁵ / ₁₆ SDAF 3164 KA x 11 ¹⁵ / ₁₆ SDAF 3264 KA x 11 ¹⁵ / ₁₆	23064 CCK/W33 23164 CACK/W33 23264 CACK/W33	SNP 3064 x 11 ¹⁵ / ₁₆ SNP 3164 x 11 ¹⁵ / ₁₆ SNP 3264 x 11 ¹⁵ / ₁₆	A 8968 ⁴⁾ A 8970 36053-137	ERF 859 ERF 900 ERF 900
12 ⁷ / ₁₆	12 1/2	SDAF 23068 KA x 12 ⁷ / ₁₆ SDAF 23168 KA x 12 ⁷ / ₁₆ SDAF 23268 KA x 12 ⁷ / ₁₆	SDAF 3068 KA x 12 ⁷ / ₁₆ SDAF 3168 KA x 12 ⁷ / ₁₆ SDAF 3268 KA x 12 ⁷ / ₁₆	23068 CACK/W33 23168 CACK/W33 23268 CCK/W33	SNP 3068 x 12 ⁷ / ₁₆ SNP 3168 x 12 ⁷ / ₁₆ SNP 3268 x 12 ⁷ / ₁₆	A 8969 ⁴⁾ 36053-137 36053-143	ERF 865 ERF 975 ERF 975
12 ¹⁵ / ₁₆	13	SDAF 23072 KA x 12 ¹⁵ / ₁₆	SDAF 3072 KA x 12 ¹⁵ / ₁₆	23072 CACK/W33	SNP 3072 x 12 ¹⁵ / ₁₆	A 8970 ⁴⁾	ERF 869
13 ⁷ / ₁₆	13 1/2	SDAF 23072 KA x 13 ⁷ / ₁₆ SDAF 23172 KA x 13 ⁷ / ₁₆ SDAF 23272 KA x 13 ⁷ / ₁₆	SDAF 3072 KA x 13 ⁷ / ₁₆ SDAF 3172 KA x 13 ⁷ / ₁₆ SDAF 3272 KA x 13 ⁷ / ₁₆	23072 CACK/W33 23172 CCK/W33 23272 CCK/W33	SNP 3072 x 13 ⁷ / ₁₆ SNP 3172 x 13 ⁷ / ₁₆ SNP 3272 x 13 ⁷ / ₁₆	A 8970 ⁴⁾ 36053-167 36053-150	ERF 872 ERF 872 ERF 979
13 ¹⁵ / ₁₆	14	SDAF 23076 KA x 13 ¹⁵ / ₁₆ SDAF 23176 KA x 13 ¹⁵ / ₁₆ SDAF 23276 KA x 13 ¹⁵ / ₁₆	SDAF 3076 KA x 13 ¹⁵ / ₁₆ SDAF 3176 KA x 13 ¹⁵ / ₁₆ SDAF 3276 KA x 13 ¹⁵ / ₁₆	23076 CACK/W33 23176 CCK/W33 23276 CCK/W33	SNP 3076 x 13 ¹⁵ / ₁₆ SNP 3176 x 13 ¹⁵ / ₁₆ SNP 3276 x 13 ¹⁵ / ₁₆	A 8971 ⁴⁾ 36053-143 36053-152	ERF 875 ERF 875 ERF 977
14 ¹⁵ / ₁₆	15	SDAF 23180 KA x 14 ¹⁵ / ₁₆ SDAF 23280 KA x 15	SDAF 3180 KA x 14 ¹⁵ / ₁₆ SDAF 3280 KA x 15	23180 CCK/W33 23280 CCK/W33	SNP 3180 x 14 ¹⁵ / ₁₆ SNP 3280 x 15	36053-150 36053-165	ERF 882 ERF 976

1) Requires different adapter sleeve and seals.

2) Optional internal radial clearance (e.g. C3) available on request.

3) For a held unit, order stabilizing rings separately.

4) Only one stabilizing ring required.

5) Optional shaft sizes available on request.

9.3 Extended range pillow blocks with spherical roller bearings on an adapter sleeve

Series SDAF 230(00) KA, 231(00) KA, 232(00) KA

d_a 15 – 19 1/2 in.

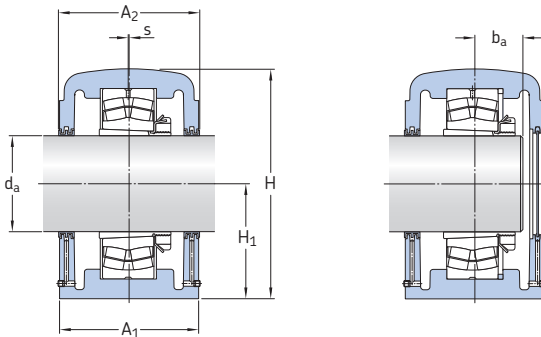

Units of measurement
In this chapter only imperial units are used. To convert imperial units to metric units, refer to the conversion table on page 10.

Shaft diameter Standard d_a	Optional ¹⁾	Complete pillow block	Components Pillow block housing	Bearing ²⁾	Adapter assembly	Stabilizing ring ³⁾ (2 req'd)	Labyrinth ring (2 incl.)
in	-	-	-	-	-	-	-
15	14 15/16	SDAF 23080 KA x 15	SDAF 3080 KA x 15	23080 CACK/W33	SNP 3080 x 15	36053-153 ⁴⁾	ERF 847
15 3/4	- ⁵⁾	SDAF 23084 KA x 15 3/4 SDAF 23184 KA x 15 3/4 SDAF 23284 KA x 15 3/4	SDAF 3084 KA x 15 3/4 SDAF 3184 KA x 15 3/4 SDAF 3284 KA x 15 3/4	23084 CAK/W33 23184 CAK/W33 23284 CAK/W33	SNP 3084 x 15 3/4 SNP 3184 x 15 3/4 SNP 3284 x 15 3/4	36053-143 ⁴⁾ 36053-160 36053-154	ERF 969 ERF 907 ERF 907
16 1/2	- ⁵⁾	SDAF 23088 KA x 16 1/2 SDAF 23188 KA x 16 1/2 SDAF 23288 KA x 16 1/2	SDAF 3088 KA x 16 1/2 SDAF 3188 KA x 16 1/2 SDAF 3288 KA x 16 1/2	23088 CAK/W33 23188 CAK/W33 23288 CAK/W33	SNP 3088 x 16 1/2 SNP 3188 x 16 1/2 SNP 3288 x 16 1/2	36053-150 ⁴⁾ 36053-165 36053-159	ERF 958 ERF 958 ERF 958
17	- ⁵⁾	SDAF 23092 KA x 17 SDAF 23192 KA x 17	SDAF 3092 KA x 17 SDAF 3192 KA x 17	23092 CAK/W33 23192 CAK/W33	SNP 3092 x 17 SNP 3192 x 17	36053-152 ⁴⁾ 36053-154	ERF 838 ERF 838
18	- ⁵⁾	SDAF 23096 KA x 18 SDAF 23196 KA x 18	SDAF 3096 KA x 18 SDAF 3196 KA x 18	23096 CAK/W33 23196 CAK/W33	SNP 3096 x 18 SNP 3196 x 18	36053-200 ⁴⁾ 36053-159	ERF 888 ERF 888
18 1/2	- ⁵⁾	SDAF 230/500 KA x 18 1/2	SDAF 30/500 KA x 18 1/2	230/500 CAK/W33	SNP 30/500 x 18 1/2	36053-165 ⁴⁾	ERF 978
19 1/2	- ⁵⁾	SDAF 230/530 KA x 19 1/2	SDAF 30/530 KA x 19 1/2	230/530 CAK/W33	SNP 30/530 x 19 1/2	36053-166 ⁴⁾	ERF 926

1) Requires different adapter sleeve and seals.

2) Optional internal radial clearance (e.g. C3) available on request.

3) For a held unit, order stabilizing rings separately.

4) Only one stabilizing ring required.

5) Optional shaft sizes available on request.

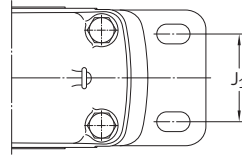
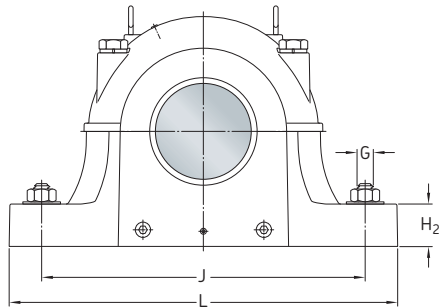

Complete pillow block
Designation

Designation	Dimensions												Mass
	A ₁	A ₂	S	b _a	H	H ₁	H ₂	J _{min}	J _{max}	J ₁	L	G	
–	in.												lb.
SDAF 23080 KA x 15	17 ¹ / ₈	17 ⁵ / ₈	3/16	5 ¹⁷ / ₃₂	29	14 ¹ / ₂	5 ¹ / ₄	40 ³ / ₄	39 ¹ / ₄	11	46	2	2300
SDAF 23084 KA x 15³/₄	17 ¹ / ₈	17 ⁵ / ₈	3/16	5 ⁹ / ₁₆	29	14 ¹ / ₂	5 ¹ / ₄	40 ³ / ₄	39 ¹ / ₄	11	46	2	2300
SDAF 23184 KA x 15³/₄	21	21 ³ / ₄	0	6 ⁷ / ₈	33 ³ / ₄	17	5 ¹ / ₂	46 ¹ / ₈	44 ³ / ₈	14 ¹ / ₂	53	2 ¹ / ₄	4300
SDAF 23284 KA x 15³/₄	21 ⁵ / ₈	22 ¹ / ₄	0	7 ¹³ / ₁₆	35 ³ / ₄	18	5 ³ / ₄	48 ⁷ / ₈	47 ¹ / ₈	15	54 ¹ / ₄	2 ¹ / ₂	5000
SDAF 23088 KA x 16¹/₂	18 ³ / ₄	19 ¹ / ₄	3/16	5 ³ / ₄	30 ¹ / ₂	15 ¹ / ₂	5 ¹ / ₂	43 ¹ / ₂	41 ³ / ₄	12 ¹ / ₄	48 ³ / ₄	2 ¹ / ₄	2550
SDAF 23188 KA x 16¹/₂	21	21 ³ / ₄	0	7 ⁷ / ₃₂	33 ³ / ₄	17	5 ¹ / ₂	46 ¹ / ₈	44 ³ / ₈	14 ¹ / ₂	53	2 ¹ / ₄	4300
SDAF 23288 KA x 16¹/₂	21 ⁵ / ₈	22 ¹ / ₄	0	8 ⁹ / ₃₂	35 ³ / ₄	18	5 ³ / ₄	48 ⁷ / ₈	47 ¹ / ₈	15	54 ¹ / ₄	2 ¹ / ₂	5050
SDAF 23092 KA x 17	18 ³ / ₄	19 ¹ / ₄	3/16	5 ⁷ / ₈	30 ¹ / ₂	15 ¹ / ₂	5 ¹ / ₂	43 ¹ / ₂	41 ³ / ₄	12 ¹ / ₄	48 ³ / ₄	2 ¹ / ₄	2850
SDAF 23192 KA x 17	21 ⁵ / ₈	22 ¹ / ₄	0	7 ¹ / ₂	35 ³ / ₄	18	5 ³ / ₄	48 ⁷ / ₈	47 ¹ / ₈	15	54 ¹ / ₄	2 ¹ / ₂	5000
SDAF 23096 KA x 18	21	21 ³ / ₄	3/16	5 ²⁹ / ₃₂	33 ³ / ₄	17	5 ¹ / ₂	46 ¹ / ₈	44 ³ / ₈	14 ¹ / ₂	53	2 ¹ / ₄	4250
SDAF 23196 KA x 18	21 ⁵ / ₈	22 ¹ / ₄	0	7 ²¹ / ₃₂	35 ³ / ₄	18	5 ³ / ₄	48 ⁷ / ₈	47 ¹ / ₈	15	54 ¹ / ₄	2 ¹ / ₂	5300
SDAF 230/500 KA x 18¹/₂	21	21 ³ / ₄	3/16	6 ¹ / ₂	33 ³ / ₄	17	5 ¹ / ₂	46 ¹ / ₈	44 ³ / ₈	14 ¹ / ₂	53	2 ¹ / ₄	4350
SDAF 230/530 KA x 19¹/₂	21 ⁵ / ₈	22 ¹ / ₄	3/16	6 ²⁷ / ₃₂	35 ³ / ₄	18	5 ³ / ₄	48 ⁷ / ₈	47 ¹ / ₈	15	54 ¹ / ₄	2 ¹ / ₂	5200

9.4 Extended range pillow blocks with spherical roller bearings on a cylindrical seat Series SDAF 230(00), 231(00), 232(00)

d_a 240 – 420 mm

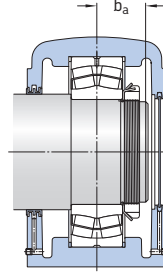
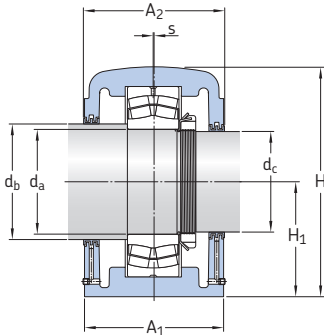

Units of measurement
In this chapter only imperial units are used. To convert imperial units to metric units, refer to the conversion table on page 10.

Shaft diameter			Complete pillow block	Components Pillow block housing	Bearing ¹⁾	Stabilizing ring ²⁾ (2 req'd)	Labyrinth Seal Shaft d_b	Shaft d_c	Lock nut	Lock washer	Mass
d_a	d_b	d_c									
240	10 1/2	9 3/16	SDAF 23248	SDAF 3248	23248 CAC/W33	36053-114	ERF 840	ERF 923	N 048	PL 48	1 100
260	11 1/2	9 15/16	SDAF 23152	SDAF 3152	23152 CAC/W33	36053-114	ERF 832	ERF 845	N 052	PL 52	1 050
	11 1/2	9 15/16	SDAF 23252	SDAF 3252	23252 CAC/W33	A 8968	ERF 832	ERF 845	N 052	PL 52	1 350
280	12 1/2	10 3/4	SDAF 23156	SDAF 3156	23156 CAC/W33	A 8967	ERF 866	ERF 826	N 056	PL 56	1 250
	12 1/2	10 3/4	SDAF 23256	SDAF 3256	23256 CAC/W33	36053-157	ERF 866	ERF 826	N 056	PL 56	1 400
300	13	11 1/2	SDAF 23060	SDAF 3060	23060 CAC/W33	A 8967 ³⁾	ERF 824	ERF 832	N 060	PL 60	1 200
	13	11 1/2	SDAF 23160	SDAF 3160	23160 CAC/W33	36053-157	ERF 846	ERF 856	N 060	PL 60	1 350
	13	11 1/2	SDAF 23260	SDAF 3260	23260 CAC/W33	36053-130	ERF 846	ERF 856	N 060	PL 60	1 900
320	13 3/4	12 1/4	SDAF 23064	SDAF 3064	23064 CC/W33	A 8968 ³⁾	ERF 943	ERF 804	N 064	PL 64	1 300
	14	12 1/4	SDAF 23164	SDAF 3164	23164 CAC/W33	A 8970	ERF 876	ERF 983	N 064	PL 64	1 850
	14	12 1/4	SDAF 23264	SDAF 3264	23264 CAC/W33	36053-137	ERF 876	ERF 983	N 064	PL 64	2 500
340	15	13	SDAF 23068	SDAF 3068	23068 CAC/W33	A 8969 ³⁾	ERF 806	ERF 824	N 068	PL 68	1 550
	15	13	SDAF 23168	SDAF 3168	23168 CAC/W33	36053-137	ERF 847	ERF 846	N 068	PL 68	2 450
	15	13	SDAF 23268	SDAF 3268	23268 CA/W33	36053-143	ERF 847	ERF 846	N 068	PL 68	2 650
360	15 3/4	13 3/4	SDAF 23072	SDAF 3072	23072 CAC/W33	A 8970 ³⁾	ERF 969	ERF 874	N 072	PL 72	1 650
	16	13 3/4	SDAF 23172	SDAF 3172	23172 CC/W33	36053-167	ERF 809	ERF 874	N 072	PL 72	2 500
	16	13 3/4	SDAF 23272	SDAF 3272	23272 CA/W33	36053-150	ERF 965	ERF 981	N 072	PL 72	2 950
380	16 3/4	14 1/2	SDAF 23076	SDAF 3076	23076 CAC/W33	A 8971 ³⁾	ERF 822	ERF 950	N 076	PL 76	1 700
	17	14 1/2	SDAF 23176	SDAF 3176	23176 CA/W33	36053-143	ERF 811	ERF 950	N 076	PL 76	2 500
	17	14 1/2	SDAF 23276	SDAF 3276	23276 CA/W33	36053-152	ERF 838	ERF 984	N 076	PL 76	3 050
400	17 1/2	15 3/8	SDAF 23080	SDAF 3080	23080 CAC/W33	36053-153 ³⁾	ERF 999	ERF 942	N 080	PL 80	2 300
	17 1/2	15 1/4	SDAF 23180	SDAF 3180	23180 CA/W33	36053-150	ERF 967	ERF 895	N 080	PL 80	2 800
	17 1/2	15 1/4	SDAF 23280	SDAF 3280	23280 CA/W33	36053-165	ERF 967	ERF 895	N 080	PL 80	4 500
420	18	16	SDAF 23084	SDAF 3084	23084 CA/W33	36053-143 ³⁾	ERF 812	ERF 809	N 084	PL 84	2 300
	18 1/2	15 3/4	SDAF 23184	SDAF 3184	23184 CA/W33	36053-160	ERF 978	ERF 907	N 084	PL 84	4 300
	18 1/2	15 3/4	SDAF 23284	SDAF 3284	23284 CA/W33	36053-154	ERF 978	ERF 907	N 084	PL 84	5 000

¹⁾ Optional internal radial clearance (e.g. C3) available on request.

²⁾ For a held unit, order stabilizing rings separately.

³⁾ Only one stabilizing ring required.

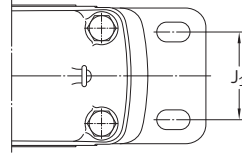
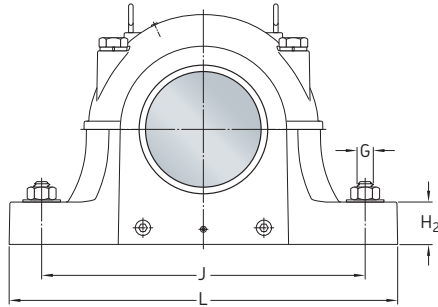

Complete pillow block

Designation	Dimensions											
	A ₁	A ₂	S	b ₃	H	H ₁	H ₂	J _{min}	J _{max}	J ₁	L	G
–	in.											
SDAF 23248	13 1/8	13 3/4		4 7/8	20 7/8	10 1/4	3 3/4	29	30 1/2	8 3/4	35	1 5/8
SDAF 23152	13 1/8	13 3/4		4 5/8	20 7/8	10 1/4	3 3/4	29	30 1/2	8 3/4	35	1 5/8
SDAF 23252	14 3/4	15 1/2		5 7/32	23 7/16	12	4	32 3/4	33 1/2	9	38 1/4	1 5/8
SDAF 23156	14 3/4	15 1/2		4 25/32	23 7/16	12	4	32 3/4	33 1/2	9	38 1/4	1 5/8
SDAF 23256	14 3/4	15 1/2		5 11/32	23 7/16	12	4	32 3/4	33 1/2	9	38 1/4	1 5/8
SDAF 23060	14 3/4	15 1/2	3/16	4 11/32	23 7/16	12	4	32 3/4	33 1/2		38 1/4	1 5/8
SDAF 23160	14 3/4	15 1/2		5 1/8	23 7/16	12	4	32 3/4	33 1/2	9	38 1/4	1 5/8
SDAF 23260	15 3/4	16 3/4		5 3/4	25 3/4	12 13/16		35	36 1/2	10 1/2	41 3/4	1 7/8
SDAF 23064	14 3/4	15 1/2	3/16	4 1/2	23 7/16	12	4	32 3/4	33 1/2		38 1/4	1 5/8
SDAF 23164	15 3/4	16 3/4		5 17/32	25 3/4	12 13/16	4 1/2	35	36 1/2	10 1/2	41 3/4	1 7/8
SDAF 23264	17 3/4	18 3/4		6 5/32	27 7/8	14	5	36 3/4	38 1/4	10 3/4	43 3/4	2
SDAF 23068	15 1/4	15 3/4	3/16	4 7/8	24	12	4 3/16	32	33 1/2	10	39	1 7/8
SDAF 23168	17 3/4	18 3/4		5 29/32	27 7/8	14	5	36 3/4	38 1/4	10 3/4	43 3/4	2
SDAF 23268	17 1/8	17 5/8		6 29/32	28 7/8	14 1/2	5 1/4	39 1/4	40 3/4	11	46	2
SDAF 23072	15 3/4	16 3/4	3/16	4 7/8	25 3/4	12 13/16	4 1/2	35	36 1/2	10 1/2	41 3/4	1 7/8
SDAF 23172	17 1/8	17 5/8		5 31/32	28 7/8	14 1/2	5 1/4	39 1/4	40 3/4	11	46	2
SDAF 23272	18 3/4	19 1/4		6 3/4	30 1/2	15 1/2	5 1/2	41 3/4	43 1/2	12 1/4	48 3/4	2 1/4
SDAF 23076	15 3/4	16 3/4	3/16	5 1/8	25 3/4	12 13/16	4 1/2	35	36 1/2	10 1/2	41 3/4	1 7/8
SDAF 23176	17 1/8	17 5/8		6 1/8	28 7/8	14 1/2	5 1/4	39 1/4	40 3/4	11	46	2
SDAF 23276	18 3/4	19 1/4		7 1/32	30 1/2	15 1/2	5 1/2	41 3/4	43 1/2	12 1/4	48 3/4	2 1/4
SDAF 23080	17 1/8	17 5/8	3/16	5 17/32	28 7/8	14 1/2	5 1/4	39 1/4	40 3/4	11	46	2
SDAF 23180	18 3/4	19 1/4		6 13/32	30 1/2	15 1/2	5 1/2	41 3/4	43 1/2	12 1/4	48 3/4	2 1/4
SDAF 23280	21	21 3/4		7 1/2	33 3/4	17	5 1/2	44 3/8	46 1/8	14 1/2	53	2 1/4
SDAF 23084	17 1/8	17 5/8	3/16	5 9/16	29	14 1/2	5 1/4	39 1/4	40 3/4	11	46	2
SDAF 23184	21	21 3/4		6 7/8	33 3/4	17	5 1/2	44 3/8	46 1/8	14 1/2	53	2 1/4
SDAF 23284	21 5/8	22 1/4		7 13/16	35 3/4	18	5 3/4	47 1/8	48 7/8	15	54 1/4	2 1/2

9.4 Extended range pillow blocks with spherical roller bearings on a cylindrical seat Series SDAF 230(00), 231(00), 232(00)

d_a 440 – 530 mm

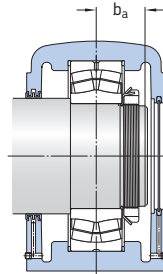
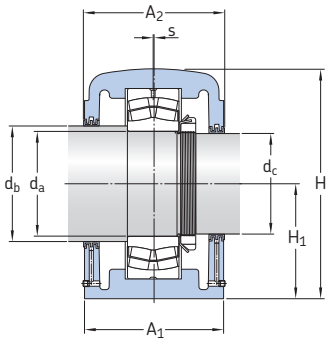

Units of measurement
In this chapter only imperial units are used. To convert imperial units to metric units, refer to the conversion table on page 10.

Shaft diameter			Complete pillow block	Components Pillow block housing	Bearing ¹⁾	Stabilizing ring ²⁾ (2 req'd)	Labyrinth seal Shaft d_b	Shaft d_c	Lock nut	Lock washer	Mass
d_a	d_b	d_c									
mm	in.		-	-							lb.
440	19 1/2	17	SDAF 23088	SDAF 3088	23088 CA/W33	36053-150	ERF 926	ERF 838	N 088	PL 88	2 550
	19 1/2	17	SDAF 23188	SDAF 3188	23188 CA/W33	36053-165	ERF 926	ERF 838	N 088	PL 88	4 300
	19 1/2	17	SDAF 23288	SDAF 3288	23288 CA/W33	36053-159	ERF 926	ERF 838	N 088	PL 88	5 050
460	20	17 3/4	SDAF 23092	SDAF 3092	23092 CA/W33	36053-152	ERF 808	ERF 906	N 092	PL 92	2 850
	20	17 3/4	SDAF 23192	SDAF 3192	23192 CA/W33	36053-154	ERF 808	ERF 906	N 092	PL 92	5 000
480	21	18 1/2	SDAF 23096	SDAF 3096	23096 CA/W33	36053-200	ERF 933	ERF 978	N 096	PL 96	4 250
	21	18 1/2	SDAF 23196	SDAF 3196	23196 CA/W33	36053-159	ERF 933	ERF 978	N 096	PL 96	5 300
500	21	19	SDAF 230/500	SDAF 30/500	230/500 CA/W33	36053-165	ERF 933	ERF 922	N 500	PL 500	4 350
530	22 1/2	20 3/8	SDAF 230/530	SDAF 30/530	230/530 CA/W33	36053-166	ERF 997	ERF 998	N 530	PL 530	5 200

¹⁾ Optional internal radial clearance (e.g. C3) available on request.

²⁾ For a held unit, order stabilizing rings separately.

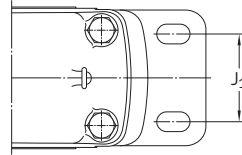
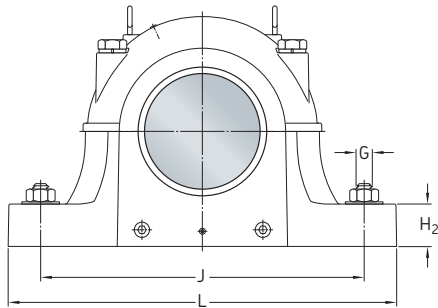

Complete pillow block

Designation	Dimensions											
	A ₁	A ₂	S	b ₃	H	H ₁	H ₂	J _{min}	J _{max}	J ₁	L	G
–	in.											
SDAF 23088	18 ³ / ₄	19 ¹ / ₄		5 ³ / ₄	30 ¹ / ₂	15 ¹ / ₂	5 ¹ / ₂	41 ³ / ₄	43 ¹ / ₂	12 ¹ / ₄	48 ³ / ₄	2 ¹ / ₄
SDAF 23188	21	21 ³ / ₄		7 ⁷ / ₃₂	33 ³ / ₄	17	5 ¹ / ₂	44 ³ / ₈	46 ¹ / ₈	14 ¹ / ₂	53	2 ¹ / ₄
SDAF 23288	21 ⁵ / ₈	22 ¹ / ₄		8 ⁹ / ₃₂	35 ³ / ₄	18	5 ³ / ₄	47 ¹ / ₈	48 ⁷ / ₈	15	54 ¹ / ₄	2 ¹ / ₂
SDAF 23092	18 ³ / ₄	19 ¹ / ₄		5 ⁷ / ₈	30 ¹ / ₂	15 ¹ / ₂	5 ¹ / ₂	41 ³ / ₄	43 ¹ / ₂	12 ¹ / ₄	48 ³ / ₄	2 ¹ / ₄
SDAF 23192	21 ⁵ / ₈	22 ¹ / ₄		7 ¹ / ₂	35 ³ / ₄	18	5 ³ / ₄	47 ¹ / ₈	48 ⁷ / ₈	15	54 ¹ / ₄	2 ¹ / ₂
SDAF 23096	21	21 ³ / ₄		5 ²⁹ / ₃₂	33 ³ / ₄	17	5 ¹ / ₂	44 ³ / ₈	46 ¹ / ₈	14 ¹ / ₂	53	2 ¹ / ₄
SDAF 23196	21 ⁵ / ₈	22 ¹ / ₄		7 ²¹ / ₃₂	35 ³ / ₄	18	5 ³ / ₄	47 ¹ / ₈	48 ⁷ / ₈	15	54 ¹ / ₄	2 ¹ / ₂
SDAF 230/500	21	21 ³ / ₄		6 ¹ / ₂	33 ³ / ₄	17	5 ¹ / ₂	44 ³ / ₈	46 ¹ / ₈	14 ¹ / ₂	53	2 ¹ / ₄
SDAF 230/530	21 ⁵ / ₈	22 ¹ / ₄		6 ²⁷ / ₃₂	35 ³ / ₄	18	5 ³ / ₄	47 ¹ / ₈	48 ⁷ / ₈	15	54 ¹ / ₄	2 ¹ / ₂